

規格及型號說明 Specification and Model Designation :

代號 Model No.	項次 Item	額定電壓 Rated Voltage	額定電流 Rated Current	材質 Material	螺絲規格 Screw Type	螺絲扭力 Screw Torsion
固定式 Solid Type	ETB25-3	600	25	PC+纖維 PC+Fiber	M3.5X8X8.8	12.2kgf.cm
	ETB25-4	600	25	PC+纖維 PC+Fiber	M3.5X8X8.8	12.2kgf.cm
	ETB25-6	600	25	PC+纖維 PC+Fiber	M3.5X8X8.8	12.2kgf.cm
	ETB25-12	600	25	PC+纖維 PC+Fiber	M3.5X8X8.8	12.2kgf.cm
組合式 Assembly Type	ETB-18 (軌式 Rail Type)	600	18	聚丙烯 Polypropylene	M3X7X7	12.0kgf.cm
	ETB-20	600	20	電木 Phenol	M3.5X8X7.8	12.2kgf.cm
	ETB-30	600	30	PC+纖維 PC+Fiber	M4X8X8.8	12.2kgf.cm
	ETB-60	600	60	電木 Phenol	M6X12	25.5kgf.cm
	ETB-100	600	100	電木 Phenol	M8X12	61.2kgf.cm
	ETB-150	600	150	電木 Phenol	M8X12	61.2kgf.cm
	ETB-200	600	200	電木 Phenol	M10X16	61.2kgf.cm
	ETB-300	600	300	電木 Phenol	M10X16	63kgf.cm
	ETB-400	600	400	電木 Phenol	M10X16	63kgf.cm



## 固定式端子盤 Solid Type Terminal Block :

• ETB- 25-3 (3P25A 600VAC)

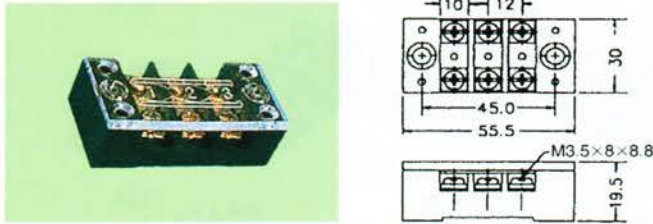

• ETB- 25-4 (4P25A 600VAC)

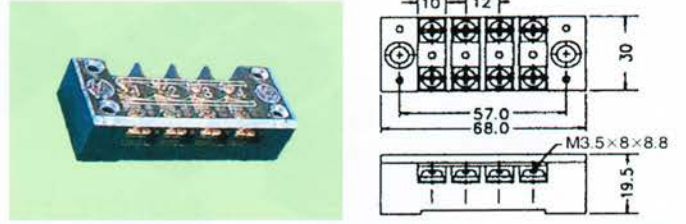

• ETB- 25-6 (6P25A 600VAC)

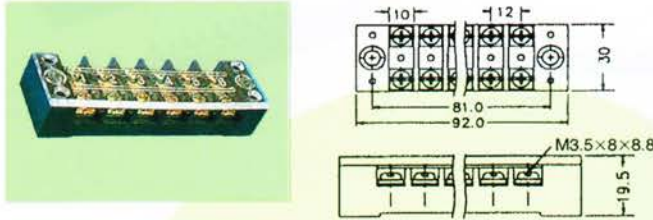

• ETB- 25-12 (12P25A 600VAC)

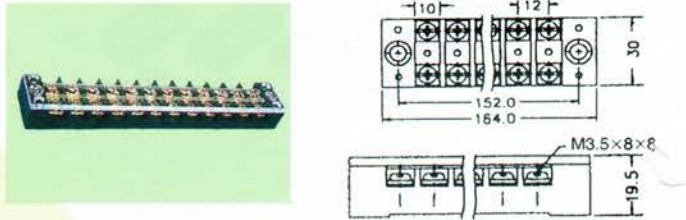

## 連結式端子盤 Connecting Type Terminal Block :

訂購說明 Order Instruction : ETB-20A(型號 Model No.) + P數/ Poles

• ETB- 20A(2p~50p)

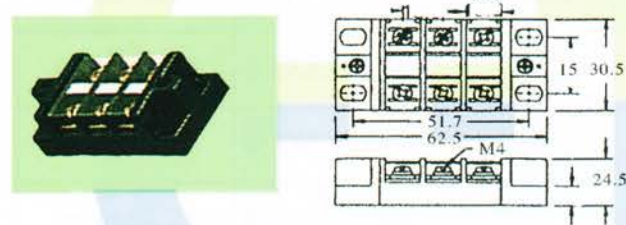

• ETB- 30A(2p~40p)

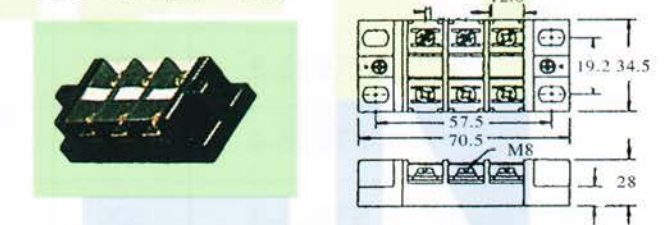

• ETB- 60A

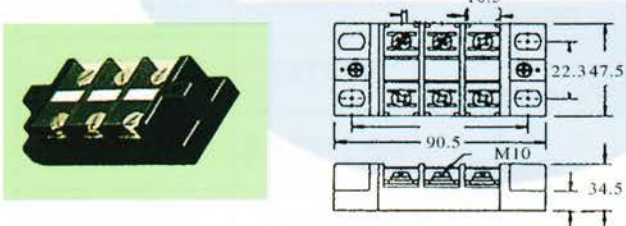

• ETB-100A

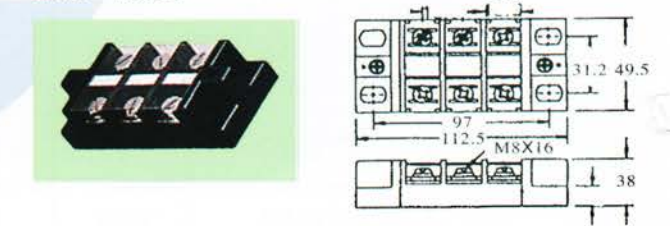

• ETB-150A

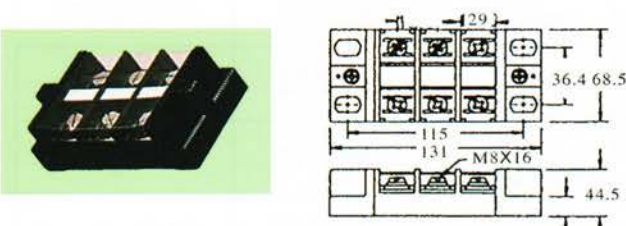

• ETB-200A

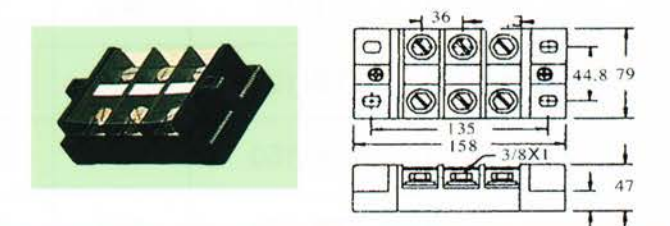

• ETB-300A

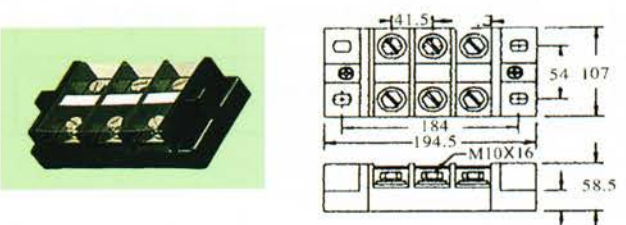

• ETB-400A

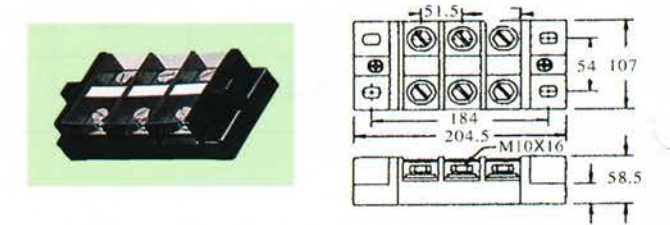



## ETU 組合式端子盤 Assembly Type Terminal Block

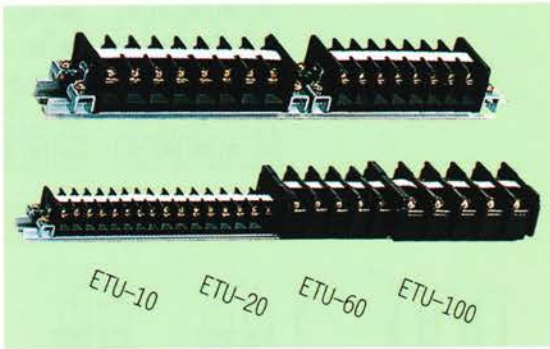

### 特性 Features :

免除傳統式串接鐵條，兩 P 直接互壓即可，安裝組立快速方便。(如圖一)  
Can be assembled without iron rod which is necessary for traditional type, and simply done the assembly by buckling two poles with each other, fast, and convenient. (Fig.1)

30P 以上長度，可任意於其間加一螺絲固定，即不變形鬆落。

Terminal blocks over 30P can fix one screw between any 2 poles to avoid deform or slip.

PC 材質，耐高溫，韌性強，不碎裂。

PC material is of high temperature endurance, high tenacity, and no spallation.

附華司螺絲，配線容易。

Easy wire distribution with washer screw.

拆卸時，以一字起子從底面溝槽撬開。(如圖三)

Easy disassembly by inserting " - "screw driver into the bottom. (Fig.3)

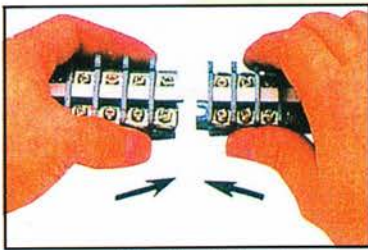

(Fig.1) (圖一)

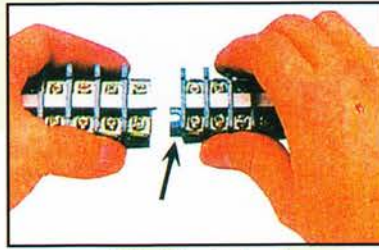

(Fig.2) (圖二)

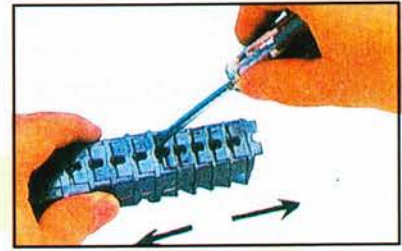

(Fig.3) (圖三)

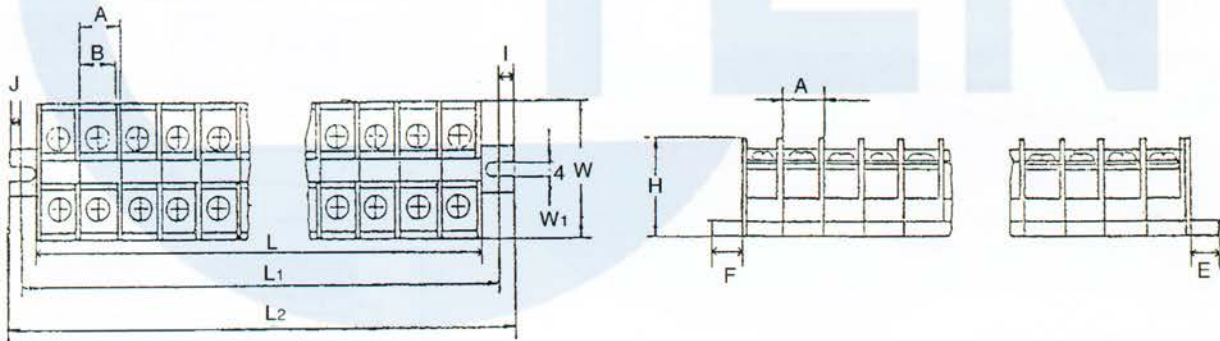

TYPE	H	S	A	B	大檔片 (C)	小檔片 (D)	E	F	I	J	L	L <sub>1</sub>	L <sub>2</sub>	材質 Material	螺絲 Screw
ETU-10	23.8	34.8	9.5	8.15	3.1	2.0	6.45	7.0	3.0	2.5	$\begin{matrix} A \\ X \\ P \\ + \\ C \\ + \\ D \end{matrix}$	L2	L + E + F	PC	M3.5×8×7.8
ETU-20	23.8	34.8	11.7	10.2	3.1	2.0	6.45	7.0	3.0	2.5				PC	M4×8×8.8
ETU-60	38.2	54.8	17.3	14.3	3.1	2.9	8.9	11.8	4.3	4.3				PC	M6×12
ETU-100	38.2	65.7	22.45	19.45	3.1	3.0	8.75	11.8	4.3	4.3				PC	M8×12

ETB-10-B 黑色巢式端子盤 Hole Type(Black) PVC(24P)

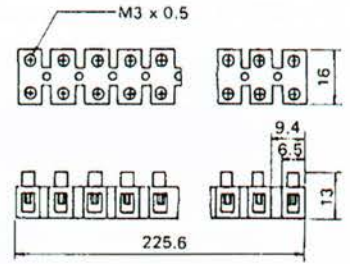
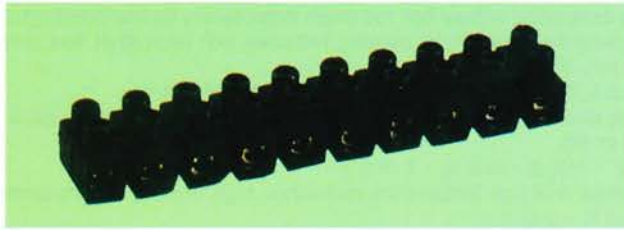

ETB-10 白色巢式端子盤 Hole Type(White) PVC(12P)

- ETB-102-8H • ETB-102-12H
- ETB-102-10H • ETB-102-14H

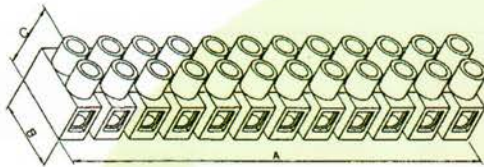
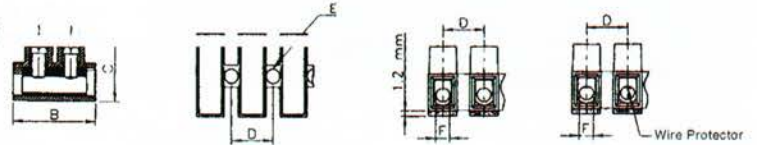

Cat. No. 訂單編號	mm <sup>2</sup> 線徑	Amp 安培	Volt. 電壓	Screw 螺絲	尺寸 Dimensions (mm/in.)							Packing 包裝
					Unit	A	B	C	D	E	F	
ETB-102-8H	1.5	17.5A	450V	M2.5×5	(mm) (in)	96.20 3.787	17.00 0.669	14.50 0.570	8.00 0.315	2.90 0.114	2.80 0.110	50 Pcs/Bag. 10 Bags/Carton
ETB-102-10H	2.5	24A	450V	M3.0×6	(mm) (in)	117.5 4.626	20.20 0.795	17.00 0.670	10.00 0.394	3.60 0.142	3.40 0.134	50 Pcs/Bag. 10 Bags/Carton
ETB-102-12H	6.0	41A	500V	M3.5×7	(mm) (in)	140.7 5.400	23.80 0.937	19.00 0.748	12.00 0.472	3.90 0.154	3.90 0.154	50 Pcs/Bag. 8 Bags/Carton
ETB-102-14H	10.0	57A	500V	M4×9	(mm) (in)	158.0 6.220	25.60 1.008	25.20 0.992	13.50 0.531	4.40 0.173	4.80 0.189	25 Pcs/Bag. 10 Bags/Carton

ETB-18A 軌式彩色端子盤 Color Rail Type PVC

- ETB-18A

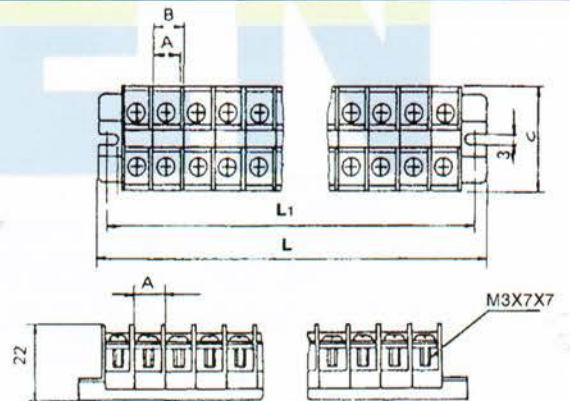
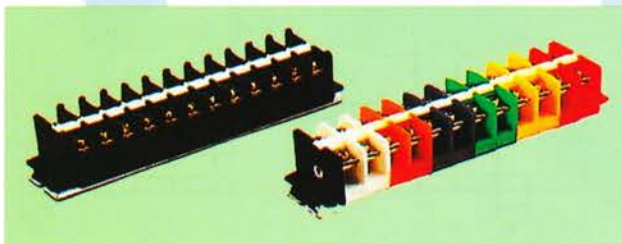

Type	A	B	C	D	L	L1	L2
ETB18A	8	9	30	22	B×P+13	B×P+8	

DTB-20(20A) 雙層軌道式端子盤 Double Layer Rail Type

DTB-20

DTB-A

DTB-B

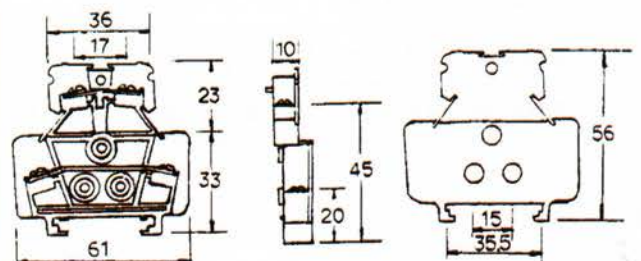





# American Style Terminal Block Screwless Terminal Block

美式端子盤、無螺絲型端子盤

## ETB-103 (10A)

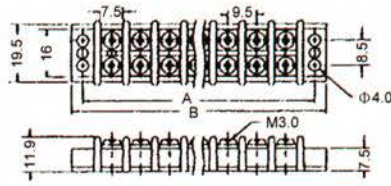
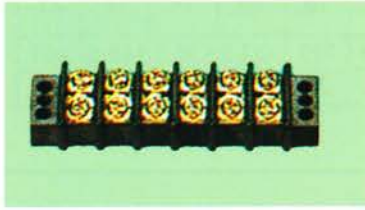

P 數 Poles	1	2	3	4	5	6	7	8	9	10	11	12	13	14
A	19	28.5	38	47.5	57	64.5	76	85.5	95	104.5	114	123.5	133	142.5
B	26.5	36	45.5	55	64.5	74	83.5	93	102.5	112	121.5	131	140.5	150

P 數 Poles	15	16	17	18	19	20	21	22	23	24	25	26	27	28
A	152	161.5	171	180.5	190	199.5	209	218.5	228	237.5	247	256.5	266	275.5
B	159.5	169	178.5	188	197.5	207	216.5	226	235.5	245	254.5	264	273.5	283

## ETB-104 (20A)

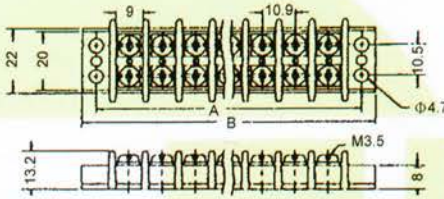
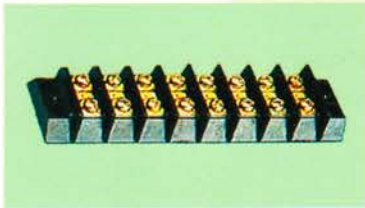

P 數 Poles	1	2	3	4	5	6	7	8	9	10	11	12	13
A	21.8	32.7	43.6	54.5	65.4	76.3	87.2	98.1	109	119.9	130.8	141.7	152.6
B	30.8	41.7	52.6	63.5	74.4	85.3	96.2	107.1	118	128.9	139.8	150.7	161.6

P 數 Poles	14	15	16	17	18	19	20	21	22	23	24	25	26
A	163.5	174.4	185.3	196.2	207.1	218	228.9	239.8	250.7	261.6	272.5	283.4	294.3
B	172.5	183.4	194.3	205.2	216.1	227	237.9	248.8	259.7	270.6	281.5	292.4	303.3

## ETB-105 (30A)

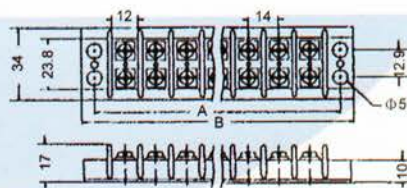
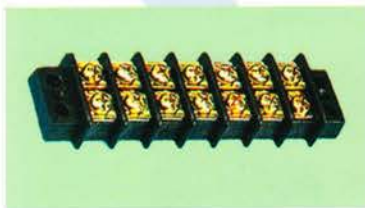

P 數 Poles	1	2	3	4	5	6	7	8	9	10	11	12
A	28	42	56	70	84	98	112	126	140	154	168	182
B	38	52	66	80	94	108	122	136	150	164	178	192

P 數 Poles	13	14	15	16	17	18	19	20	21	22	23	24
A	196	210	224	238	252	266	280	294	308	322	336	350
B	206	220	234	248	262	276	290	304	318	332	346	360

## TTB(10A) 無螺絲型插式端子盤 Screwless Insert Type

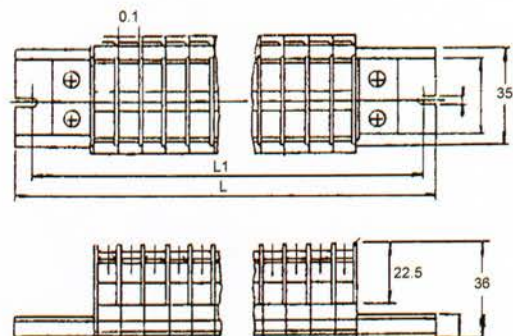
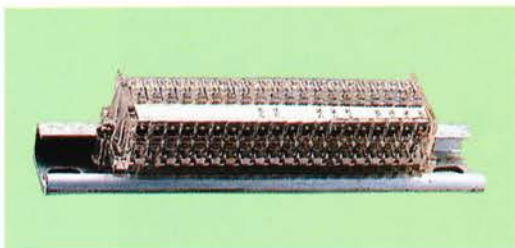



# Earthing Type Terminal Block European Style Terminal Block

接地端子盤、歐式端子盤

GTB 接地端子盤 Earthing Type



P 數 Poles	3	4	5	6	7	9	11	13	15	17	19	21
L	50.4	62	74.2	84	100	85.9	98.4	110	123.5	136.5	148.5	161
H	12	12	12	12	12	24	24	24	24	24	24	24

ATB 歐式端子盤 Screw Clamp Terminal Block Clip-On Mounting 2.5mm<sup>2</sup>~70mm<sup>2</sup>

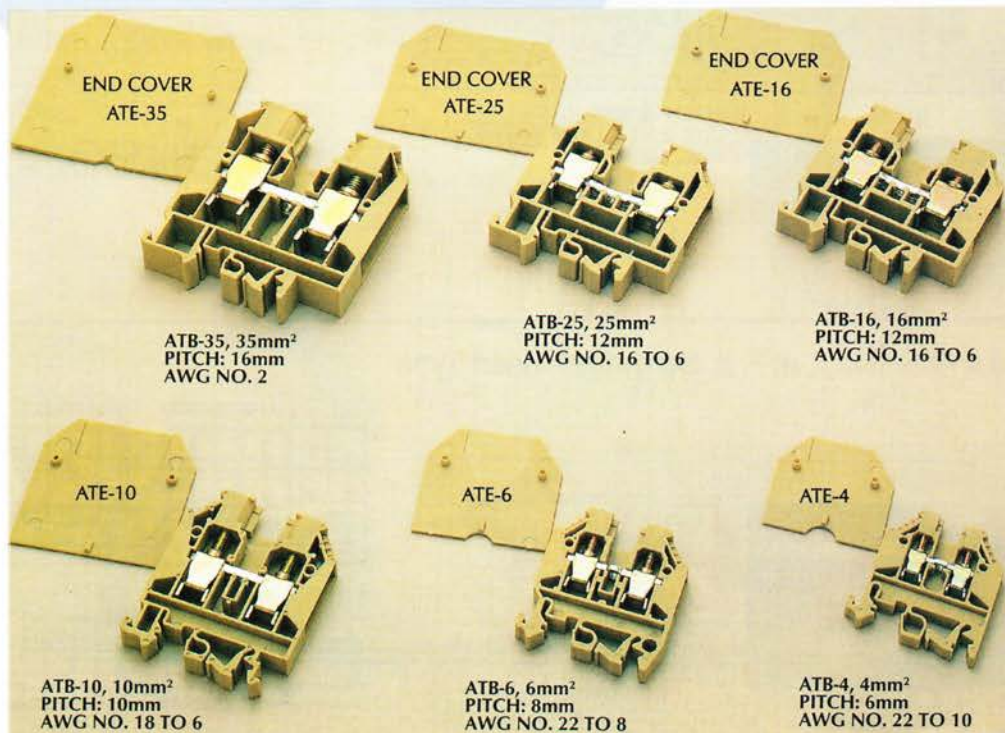
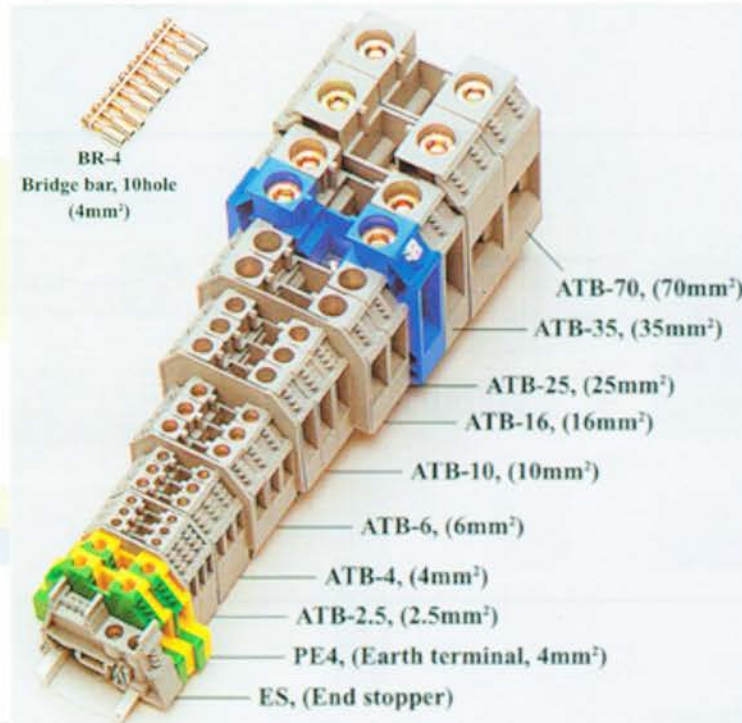



• ATB-4 4mm<sup>2</sup>



PITCH : 6mm  
CURRENT : 30AMP 600VAC  
AWG NO. 22 TO 10

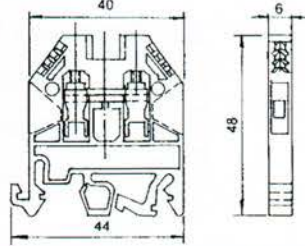

• ATB-6 6mm<sup>2</sup>



PITCH : 6mm  
CURRENT : 40AMP 600VAC  
AWG NO. 22 TO 8

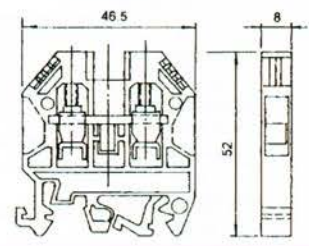

ATB-2.5

PITCH : 5mm  
CURRENT : 26AMP 600VAC  
AWG NO. 22 TO 12

• ATB-10 10mm<sup>2</sup>



PITCH : 9.8mm  
CURRENT : 60AMP 600VAC  
AWG NO. 18 TO 6

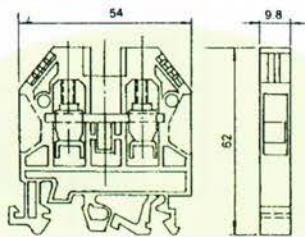

• ATB-16 16mm<sup>2</sup>



PITCH : 12mm  
CURRENT : 75AMP 600VAC  
AWG NO. 14 TO 6

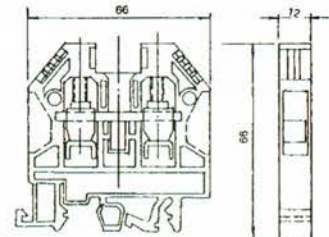

• ATB-35 35mm<sup>2</sup>



PITCH : 16mm  
CURRENT : 100AMP 600VAC  
AWG NO. 12 TO 2

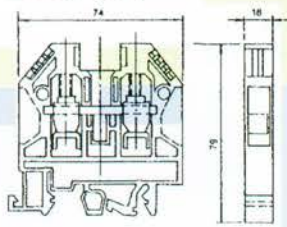

• END. STOPPER

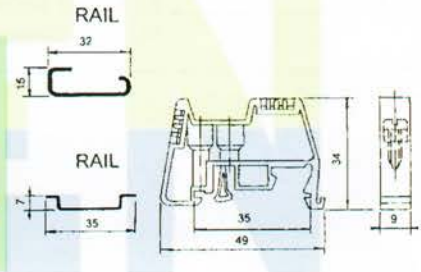

CABLE MARKER

0. 1. 2. 3. 4. 5. 6. 7. 8. 9.  
A. B. C. D. E. F. G. H. I. J. K. L. M. N. O. P.  
Q. R. S. T. U. V. W. X. Y. Z.

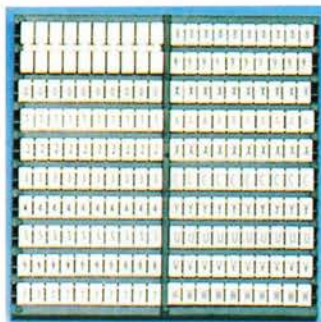
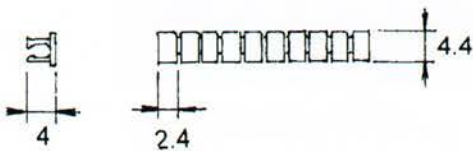

• ATB-70 70mm<sup>2</sup>



PITCH : 24mm  
CURRENT : 207AMP 600VAC  
AWG NO. 3/0

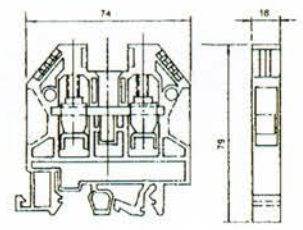

• PE-4 4mm<sup>2</sup>



EARTH TERMINAL BLOCK  
CURRENT : 30AMP  
AWG NO. 22 TO 10

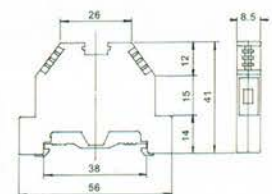

ETB-10 孔距 Pitch : 10mm

特性 Specification :

材質 Material	熱塑性塑膠 Thermoplastic (UL 94V-0) Black
端子材質 Terminal Material	鍍錫銅 Tin Plated Brass
螺絲材質 Screw Material	鍍錫鋼 Nickel Plated Steel
線徑 Wire Range AWG	14 ~ 22 Str.
額定值 Rated Capacity	AC300V · 15A
絕緣電阻 Insulation Resistance	DC500V 之下 · 500mΩ 以上 Over 500mΩ under DC500V
耐電壓 Dielectric Strength	AC2000V 一分鐘 AC2000V for 1 minute

圖面 Dimension : ±0.8mm

孔 Pole	ETB-10-□P	ETB-10-□PH
A	(P×10)+1.8	(P+2)×10+1.8
B	(P-1)×10	(P+1)×10

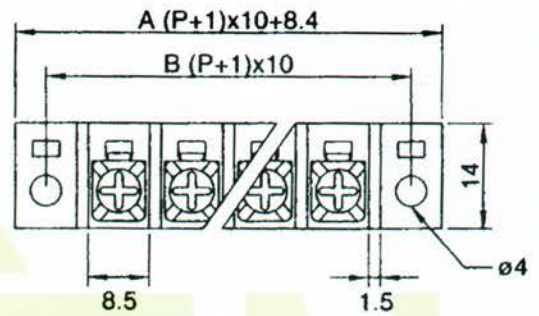

訂購須知 Order Guide :

ETB-10□-□P□-□

- S : 附邊鋼 Plate
- H : 附固定孔 With Mounting Hole  
(O、D、E、F、G、H 為必要 / Necessary)
- 2 ~ 26P Pole Size
- 型號 Model No.
- ETB 材質 Material : 電木 Phenol
- PL 材質 Material : 熱塑性塑膠 Thermoplastic

• ETB-10-0

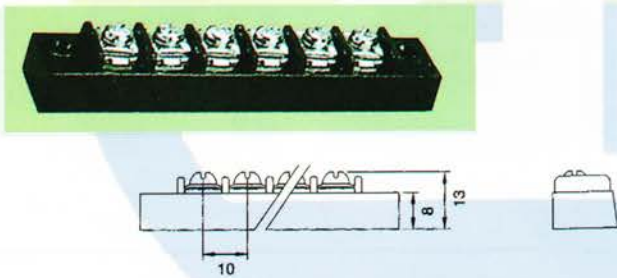

• ETB-10-C

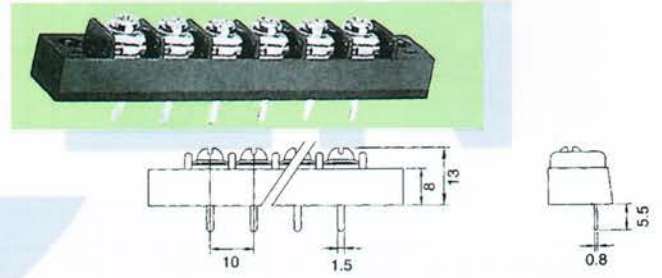

• ETB-10-A

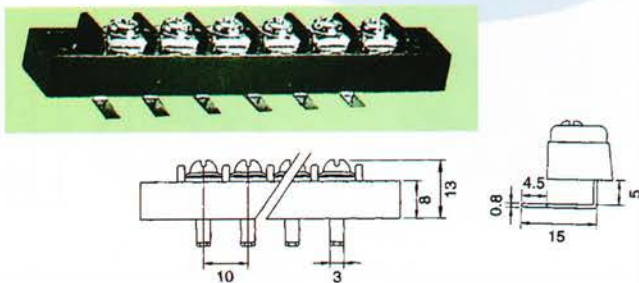

• ETB-10-D

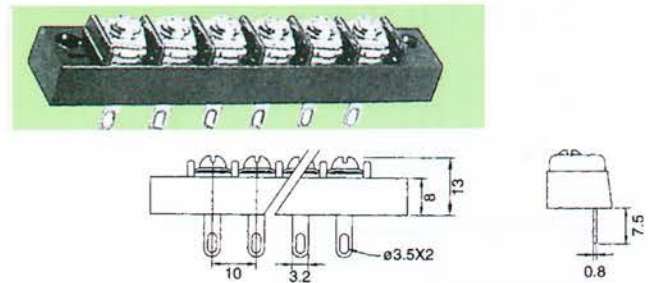

• ETB-10-B

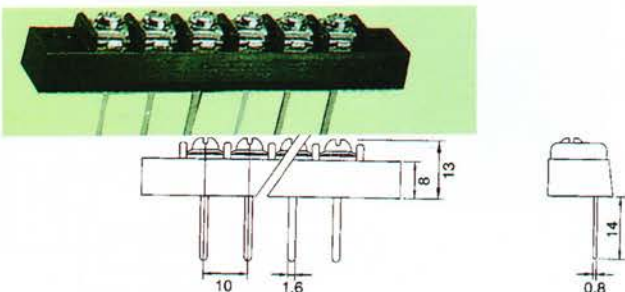

• ETB-10-E

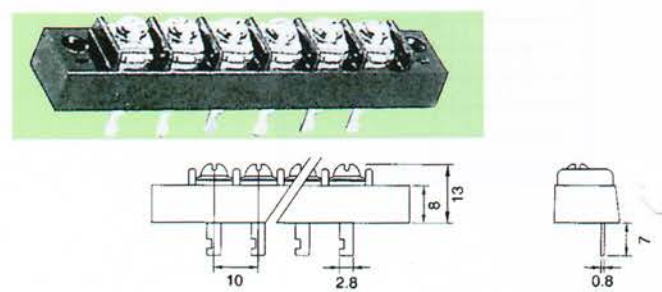



HI-201 孔距 Pitch : 9.5mm

特性 Specification :

材質 Material	熱塑性塑膠 Thermoplastic (UL 94V-0) Black
端子材質 Terminal Material	鍍錫銅 Tin Plated Brass
螺絲材質 Screw Material	鍍錫鋼 Nickel Plated Steel
線徑 Wire Range AWG	14 ~ 22 Str.
額定值 Rated Capacity	AC300V · 15A
絕緣電阻 Insulation Resistance	DC500V 之下 · 500mΩ 以上 Over 500mΩ under DC500V
耐電壓 Dielectric Strength	AC2000V 一分鐘 AC2000V for 1 minute

圖面 Dimension : ±0.8mm

孔 Pole	HI-20-□P	HI-20-□PH
A	(P×9.5)+2.1	(P+2)×9.5+2.1
B	(P-1)×9.5	(P+1)×9.5

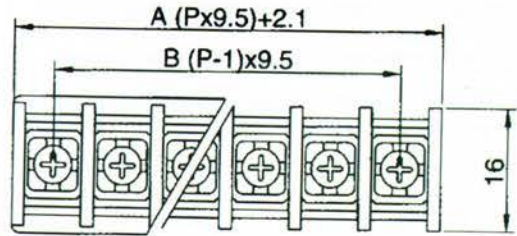

訂購須知 Order Guide :

HI-20□-□P□-□□

- S : 附邊鋼 Plate
- C : 附蓋子 With Cover
- H : 附固定孔 With Mounting Hole  
(200、205 為必要 / Necessary)
- 2 ~ 32P Pole Size
- 型號 Model No.

● HI-201

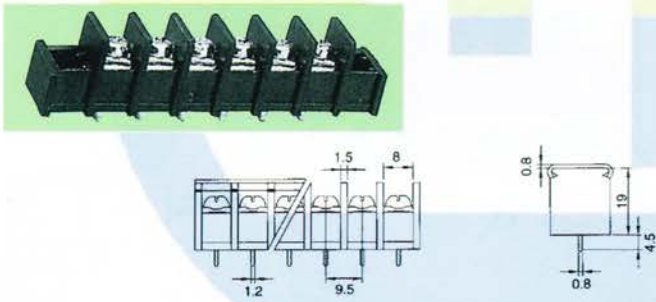

● HI-204

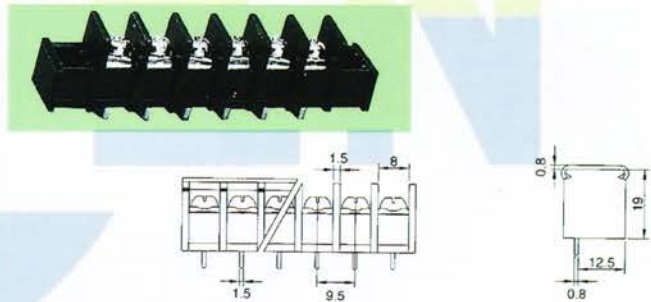

● HI-202

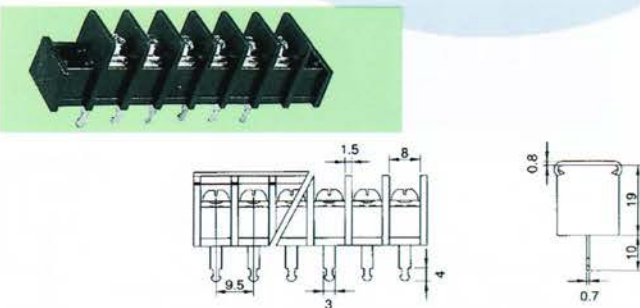

● HI-205

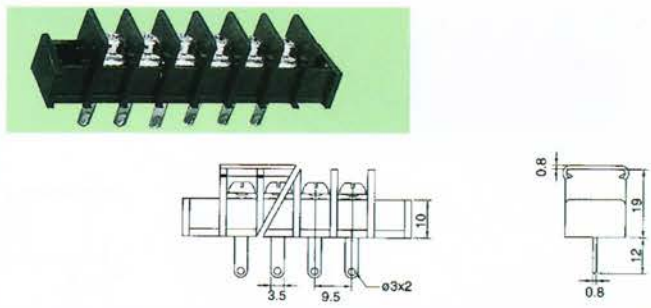

● HI-203

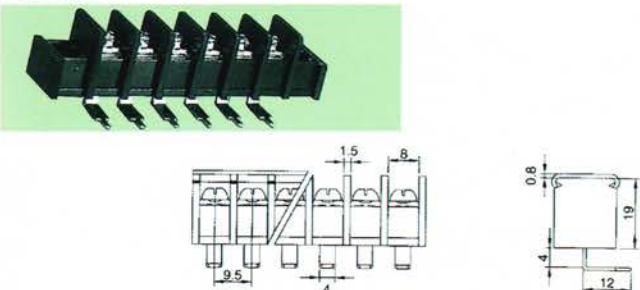

FTB-701 孔距 Pitch : 7.62mm

特性 Specification :

材質 Material	熱塑性塑膠 Thermoplastic (UL 94V-0) Black
端子材質 Terminal Material	鍍錫銅 Tin Plated Brass
螺絲材質 Screw Material	鍍鎳鋼 Nickel Plated Steel
線徑 Wire Range AWG	18 ~ 22 Str.
額定值 Rated Capacity	AC300V · 10A
絕緣電阻 Insulation Resistance	DC500V 之下 · 500mΩ 以上 Over 500mΩ under DC500V
耐電壓 Dielectric Strength	AC2000V 一分鐘 AC2000V for 1 minute

圖面 Dimension : ±0.8mm

孔 Pole	FTB-70-□P	FTB-70-□PH
A	(P×7.62)+1.52	(P+2)×7.62+0.04
B	(P-1)×7.62	(P+1)×7.62

訂購須知 Order Guide :

FTB-70□□P□□□

- S : 附邊銅 Plate
- C : 附蓋子 With Cover
- H : 附固定孔 With Mounting Hole  
(700、705 為必要 / Necessary)
- 2 ~ 32P Pole Size
- 型號 Model No.

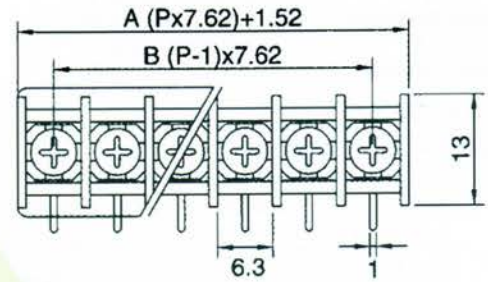

● FTB-701

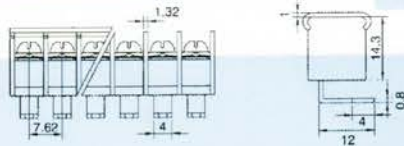
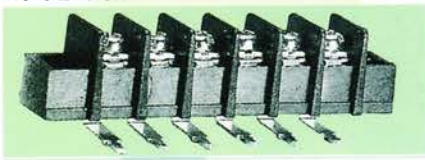

● FTB-704

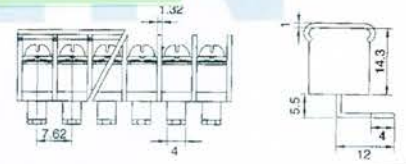
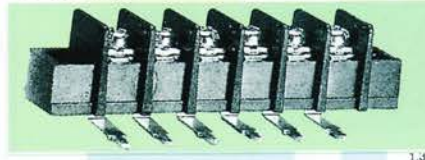

● FTB-702

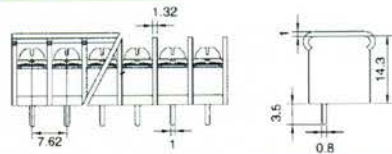

● TB-705

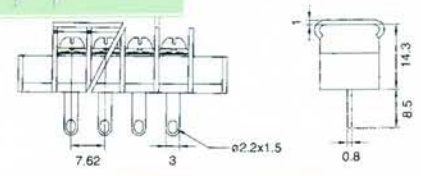

● FTB-703

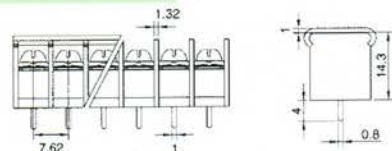



FTB-80 孔距 Pitch : 8.25mm

特性 Specification :

材質 Material	熱塑性塑膠 Thermoplastic (UL 94V-0) Black
端子材質 Terminal Material	鍍錫銅 Tin Plated Brass
螺絲材質 Screw Material	鍍鎳鋼 Nickel Plated Steel
線徑 Wire Range AWG	16 ~ 22 Str.
額定值 Rated Capacity	AC300V · 15A
絕緣電阻 Insulation Resistance	DC500V 之下 · 500mΩ 以上 Over 500mΩ under DC500V
耐電壓 Dielectric Strength	AC2000V 一分鐘 AC2000V for 1 minute

圖面 Dimension : ±0.8mm

孔 Pole	FTB-80-□P	FTB-70-□PH
A	(P×8.25)+2	(P+2)×8.25+2
B	(P-1)×8.25	(P+1)×8.25

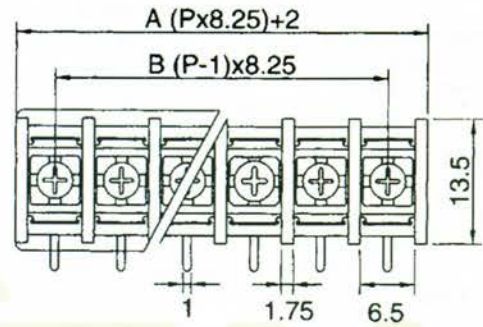

訂購須知 Order Guide :

FTB-80□□P□□□

- S : 附邊銅 Plate
- C : 附蓋子 With Cover
- H : 附固定孔 With Mounting Hole  
(803 為必要 / Necessary)
- 2 ~ 32P Pole Size
- 型號 Model No.

● FTB-801

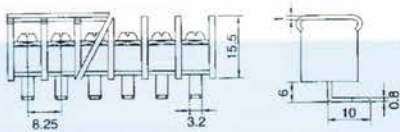
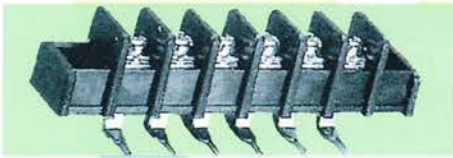

● FTB-804

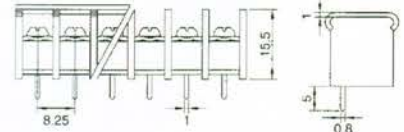

● FTB-802

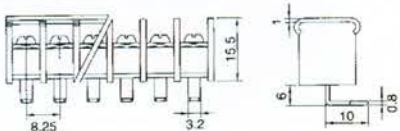

● FTB-805

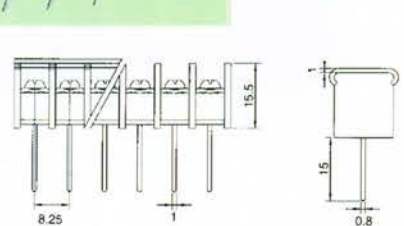

● FTB-803

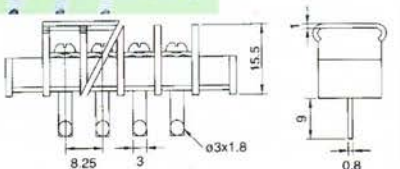

HB-95 孔距 Pitch : 9.5mm

特性 Specification :

材質 Material	熱塑性塑膠 Thermoplastic (UL 94V-0) Black
端子材質 Terminal Material	鍍錫銅 Tin Plated Brass
螺絲材質 Screw Material	鍍銀鋼 Nickel Plated Steel
線徑 Wire Range AWG	18 ~ 22 Str.
額定值 Rated Capacity	AC300V · 15A
絕緣電阻 Insulation Resistance	DC500V 之下 · 500mΩ 以上 Over 500mΩ under DC500V
耐電壓 Dielectric Strength	AC2000V 一分鐘 AC2500V for 1 minute

訂購須知 Order Guide :

HB-95 □ - □ P □ - □

- S : 附邊銅 Plate
- H : 附固定孔 With Mounting Hole  
(953 為必要 / Necessary)
- 2 ~ 32P Pole Size
- 型號 Model No.

圖面 Dimension : ±0.8mm

孔 Pole	HB-95-□P	HB-95-□PH
A	$(P \times 9.5) + 1.5$	$(P+2) \times 9.5 + 1.5$
B	$(P-1) \times 9.5$	$(P+1) \times 9.5$

● HB-951

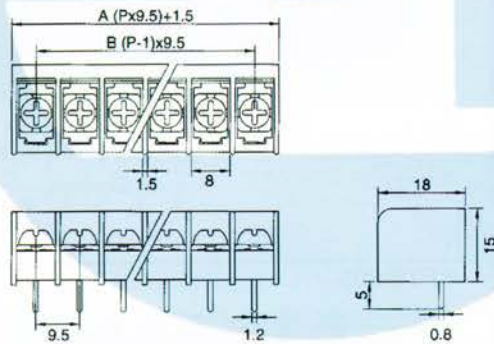
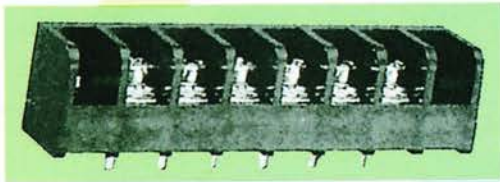

● HB-953

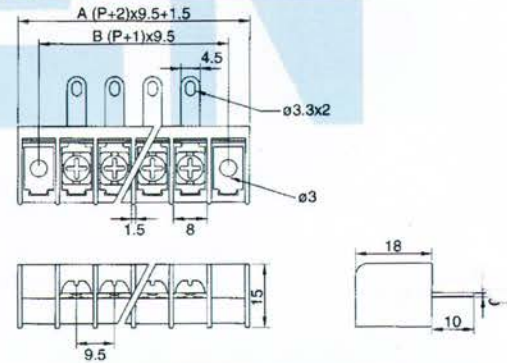

● HB-952

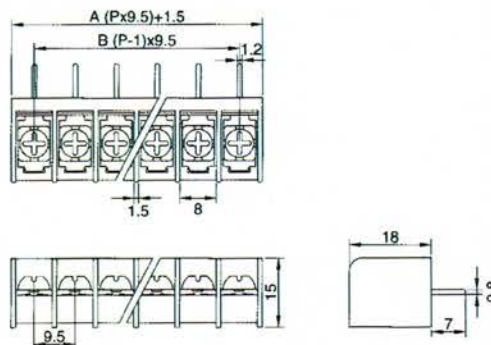
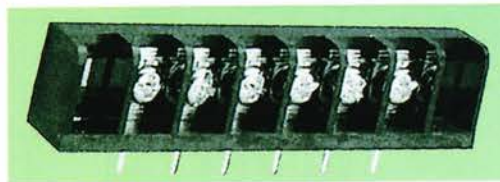

● HB-954

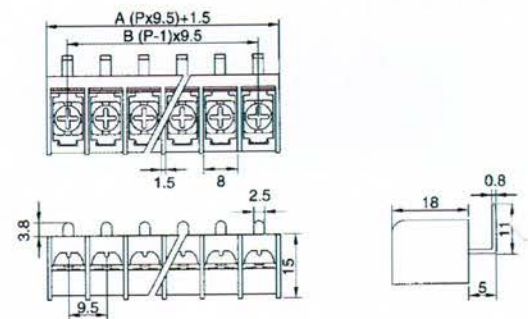
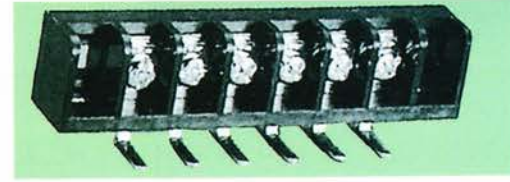



ES-50 孔距 Pitch : 5mm

特性 Specification :

材質 Material	熱塑性塑膠 Thermoplastic (UL 94V-0) Green
端子材質 Terminal Material	鍍錫銅 Tin Plated Brass
螺絲材質 Screw Material	鍍鋅鋼 Zinc Plated Steel
線徑 Wire Range AWG	16 ~ 22 Str.(ES-501 · 502 · 503) 14 ~ 18 Str.(ES-504)
額定值 Rated Capacity	AC250V · 10A
絕緣電阻 Insulation Resistance	DC500V 之下 · 500mΩ 以上 Over 500mΩ under DC500V
耐電壓 Dielectric Strength	AC2000V 一分鐘 AC2000V for 1 minute

ES-501

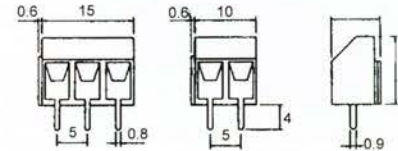
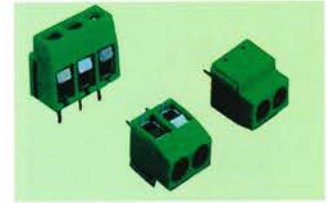

ES-502

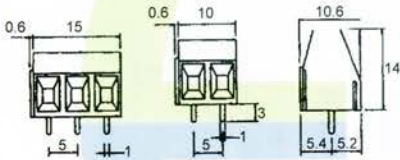
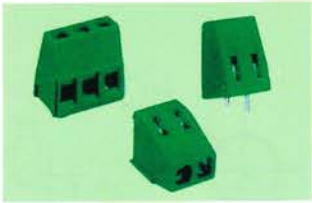

ES-503

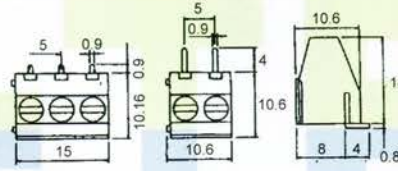

ES-504

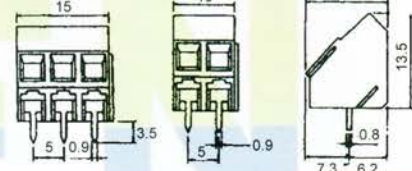

ED-51 孔距 Pitch : 5mm or 7.62mm

特性 Specification :

材質 Material	熱塑性塑膠 Thermoplastic (UL 94V-0) Green
端子材質 Terminal Material	鍍錫銅 Tin Plated Brass
扳子材質 Lever Material	熱塑性塑膠 Thermoplastic (UL 94V-0) Orange
線徑 Wire Range AWG	14 ~ 18 Str.
額定值 Rated Capacity	AC250V · 10A
絕緣電阻 Insulation Resistance	DC500V 之下 · 500mΩ 以上 Over 500mΩ under DC500V
耐電壓 Dielectric Strength	AC2000V 一分鐘 AC2000V for 1 minute

ED-511

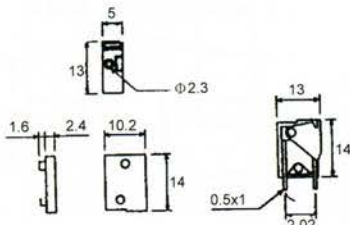
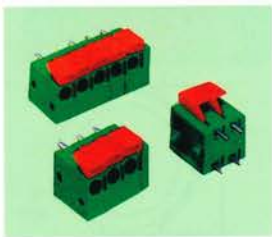

ED-512

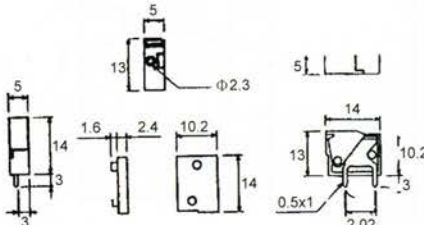
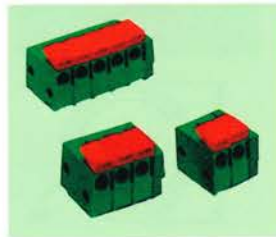

ED-513

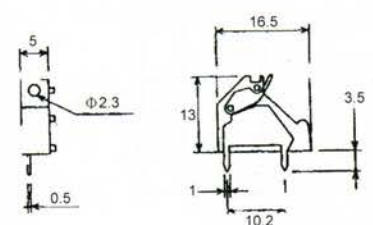
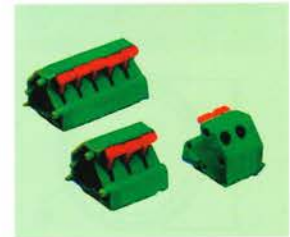

# Testing Terminal Block Isolated Phenol Base

測試端子、獨立電木座

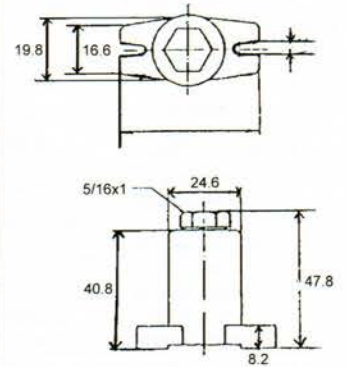
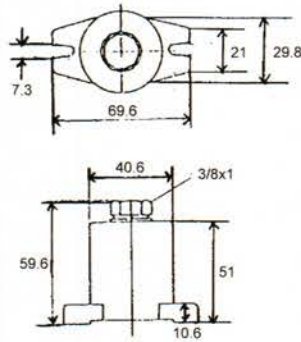

- P.T.T. (P-1) 電壓測試端子 Voltage Testing Terminal Block
- C.T.T. (P-2) 電流測試端子 Current Testing Terminal Block

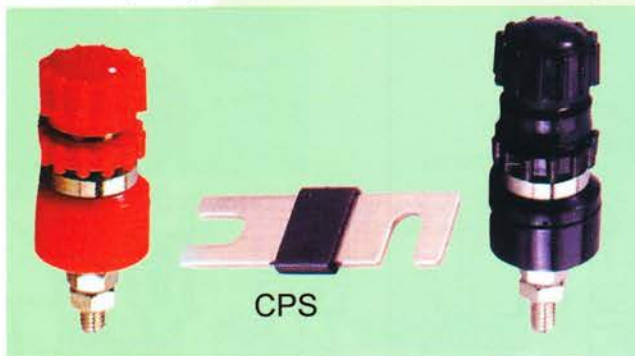

P.T.T.  
(P-1)

C.T.T.  
(P-2)

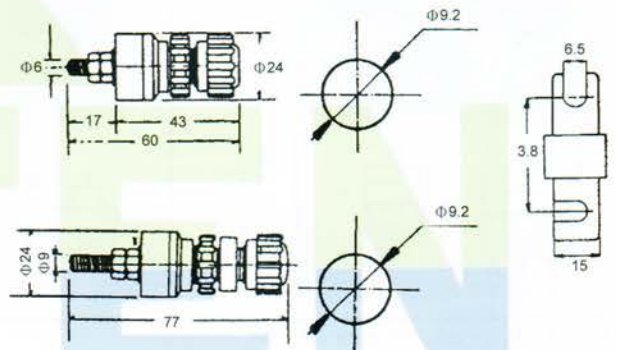

- 銅排支架礙子  
Bus Bar Support Insulator

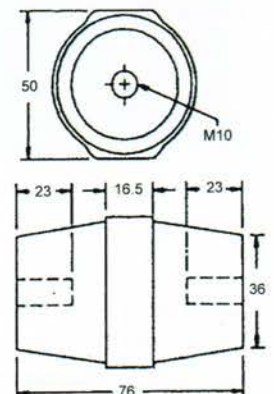
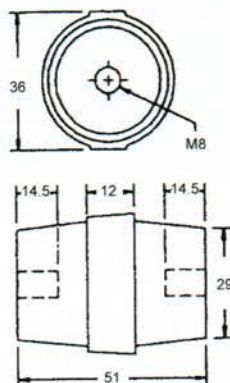
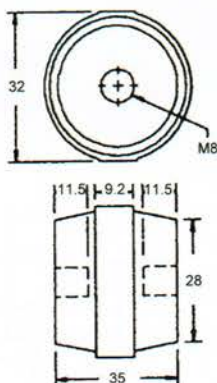



BS-100

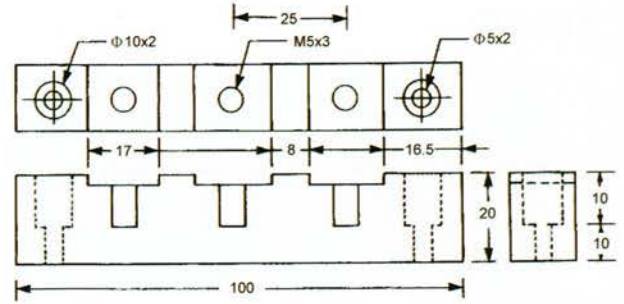
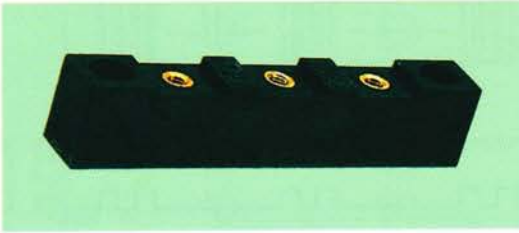

BS-130

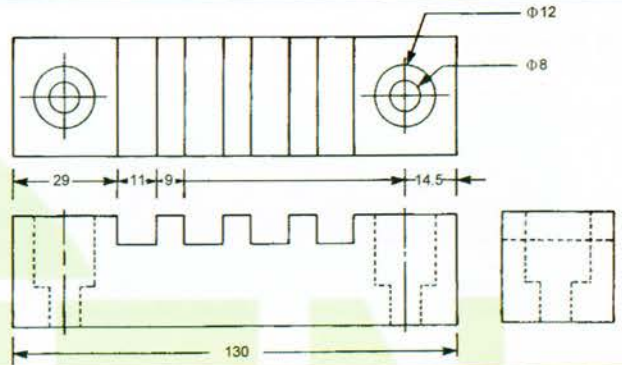
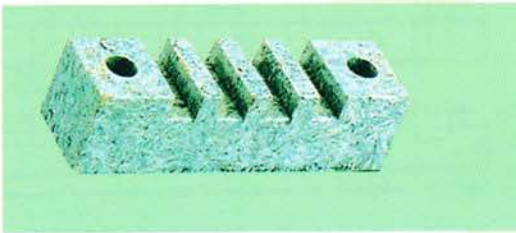

BS-140

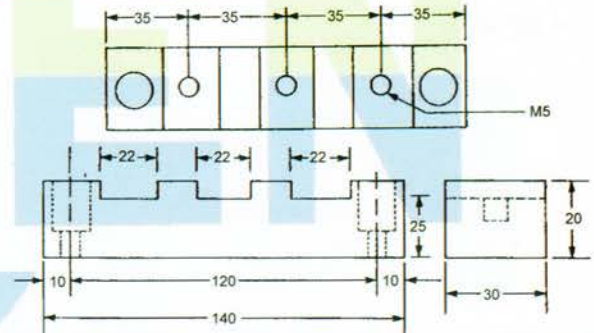
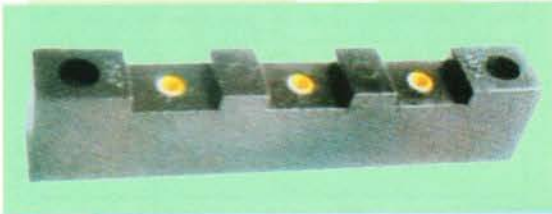

BS-180A,180B

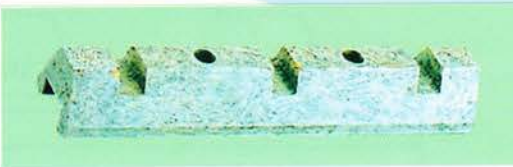

BS-180A 銅排架凹槽 Bus Bar Support Fillister 60.3mm  
BS-180B 銅排架凹槽 Bus Bar Support Fillister 11mm

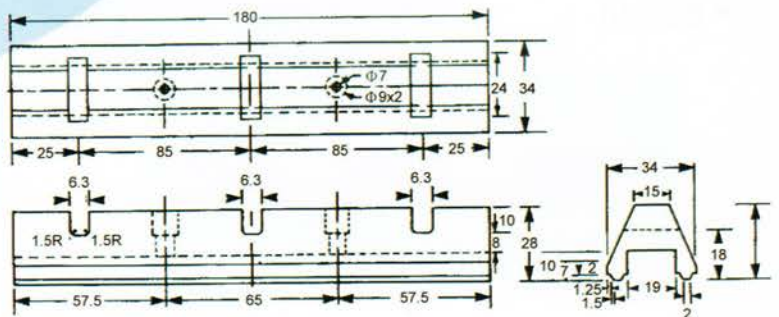

BS-210

