

Power Push Button Switch

MP 系列動力押扣開關，專為控制機械而設計，金屬烤漆外殼，純銀鎘接點，通導優良，堅固耐用。MP series power push button switches are designed for machinery operation and control. The silver cadmium contact block provides excellent induction, and the painted metal case offers strength and durability.

型式 Type	MP-310	MP-315、MSP-315	MP-330、MSP-330	MS-345、MS-346
接點容量 Contact Capacity	AC500V/ 10A	AC500V/ 15A	AC500V/ 30A	AC500V/ 20A
最大電壓 Max. Voltage	AC600V			
接觸電阻 Contact Resistance	20mΩ 以下 (初期值) Below 20mΩ(Initial)			
絕緣電阻 Insulation Resistance	DC500V 之下，100mΩ 以上 Over 100mΩ under DC500V			
耐電壓 Dielectric Strength	AC1500V 一分鐘 AC1500V for 1 minute			
操作頻率 Operation Frequency	300 回/ 小時 300 times/ hr			
壽命 Service Life	機械 Mechanical	100,000 次/ 100,000 times		
	電氣 Electric	50,000 次/ 50,000 times		

• PMP-315(塑殼)PLASTIC CASE

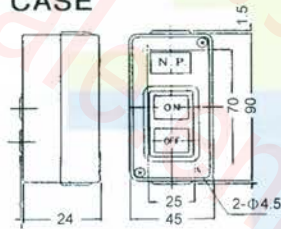

• MSP-315

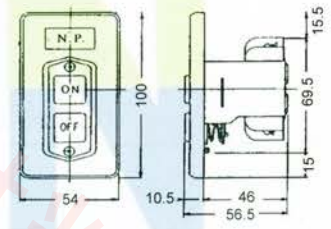

埋入式Submerged Type

• MP-310

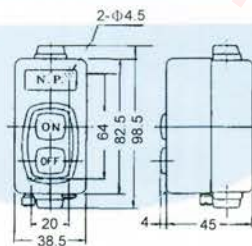

• MSP-330

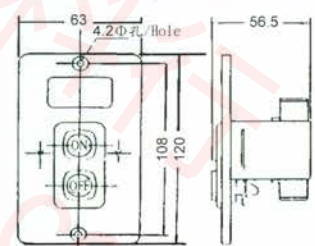

埋入式Submerged Type

• MP-315

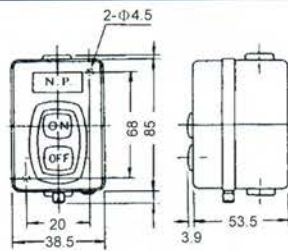

• MS-345

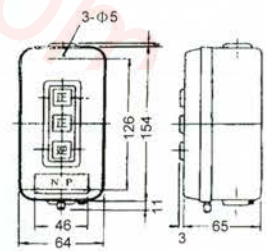

露出式Emerged Type

• MP-330

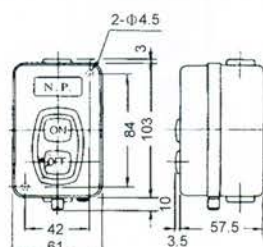

• MS-346

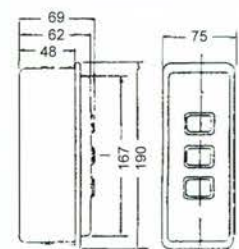

埋入式Submerged Type

動力押扣開關

Operation Push Button Switch

操作作用押扣開關

PB-2

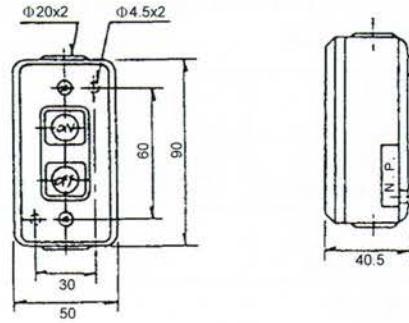

露出埋入兩用型Both Compatible for Emerged & Submerged Type

PB-3

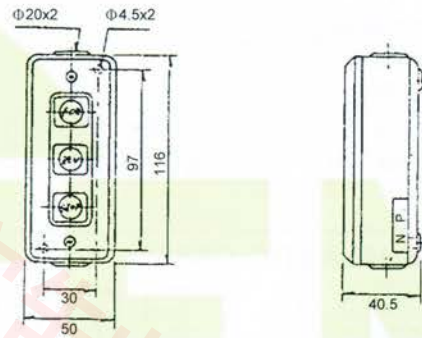

露出埋入兩用型Both Compatible for Emerged & Submerged Type

PB-3A

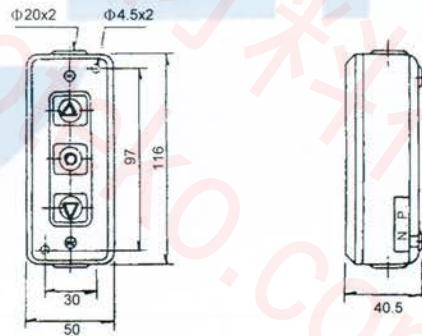

露出埋入兩用型Both Compatible for Emerged & Submerged Type

PB-3S **NEW**

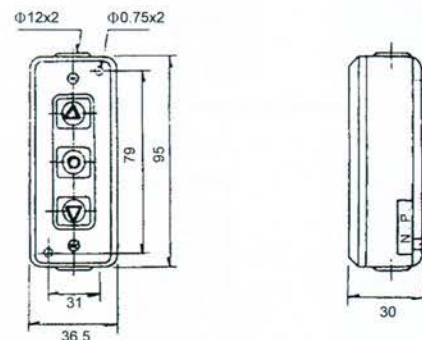



Buzzer、Bell、Siren

蜂鳴器、警鈴、警報器

型號說明 Model Designation :

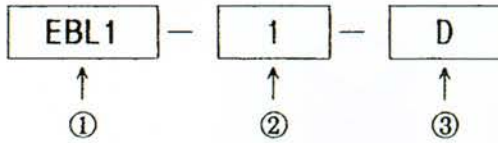

音量 Voice Volume

EBL1 : 75分貝以上 Over 75db

EBL2、EBL3 : 85分貝以上 Over 85db

EBL4 : 95分貝以上 Over 95db

項次 Item	代號 Model No.	說明 Description				
1. 型式 Type	EBL1	Φ30mm Buzzer		Φ30mm 蜂鳴器		
	EBL2	Emerged Type Buzzer		露出型蜂鳴器		
	EBL3	Submerged Type Buzzer		埋入型蜂鳴器		
	EBL4	4" Siren		4" 警鈴		
	EBLR4	4" Siren (Red)		4" 警鈴(紅)		
	EBL5	Electronic Siren 10~15W 100db		電子式警報器		
	EBL6	Motor Siren 110V 0.4A 120±5db		馬達式警報器		
	EBL6DS	Motor Double Siren 3db		雙向馬達式警報器		
	EBL7	Motor Siren 120db		馬達式警報器		
	MS	Motor Siren 200db		馬達式警報器		
	EBL1A	Volume Adjustable Internal Buzzer AC		EBL1 音量可調式內臟 AC		
	EBL23A	Volume Adjustable Internal Buzzer DC		EBL2.3 音量可調式內臟 DC		
	EA-50	Police Siren 50W		車用警報喊話器 50W		
	EA-70	Police Siren 70W		車用警報喊話器 70W		
	EA-100	Police Siren 100W		車用警報喊話器 100W		
2. 電壓 Voltage	1	110V	2	220V	3	380V
	4	440V	7	AC24V(D C)	9	AC12V(DC)
3. 電流 Ampere	A	AC 交流電 Alternate Current				
	D	DC 直流電 Direct Current				

型式 Type	額定電壓/ 電流 Ratings		耐電壓 Dielectric Strength	絕緣阻抗 Insulation Resistance	持續使用時間 Continuous Service Life
EBL1	AC110V/ 42mA	AC220V/ 22mA	AC1500V 一分鐘 AV1500V 1 Minute	DC500V 以下 100mΩ 以上 Under DC500V Over 100mΩ	30 分鐘 30 Minutes
EBL2	AC24V/ 42mA	DC6V/ 1mA			
EBL3	AC48V/ 200mA AC110V/ 100mA AC220V/ 50mA	DC12V/ 550mA DC24V/ 270mA DC48V/ 135mA			

Buzzer、Bell、Siren

蜂鳴器、警鈴、警報器

EBL-1 (Φ30mm)

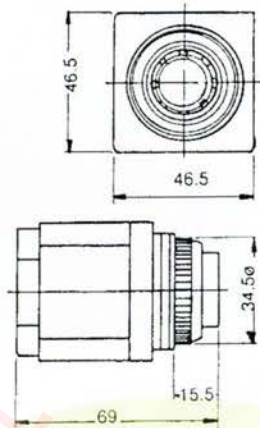

EBL-1N (音量可調Volume Adjustable) NEW

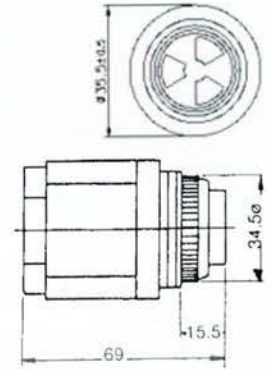

EBL-2 A: 連續聲Continuous
B: 間歇聲Interim

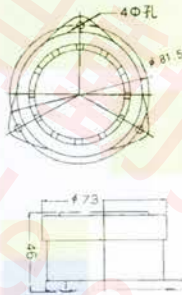

EBL-3 A: 連續聲Continuous
B: 間歇聲Interim

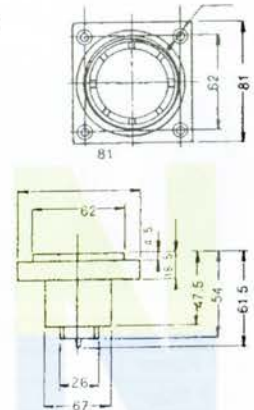
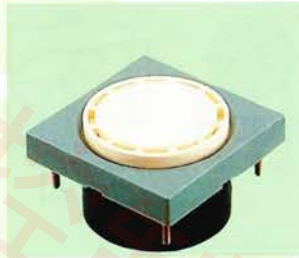

EBL-1A (音量可調Volume Adjustable)

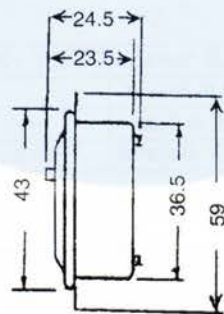

EBL-23A (DC用For Direct Current)

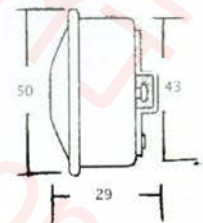

EBL-4

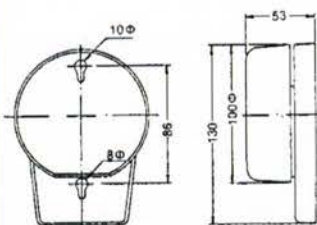

EBL-5 A: 消防聲Fire Truck
B: 警車聲Squad Car
C: 防盜聲Alarm

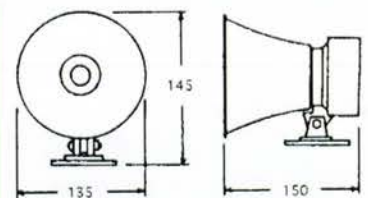

電壓 Voltage	DC12V · DC24V · AC110V · AC220V
功率 Power	10W
尺寸 Size	5"
材質 Material	ABS



Buzzer、Bell、Siren

蜂鳴器、警鈴、警報器

• EBL-6

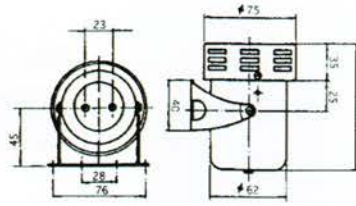

電壓 Voltage	DC12V、DC24V、AC110V、AC220V
功率 Power	10W
材質 Material	鐵質烤漆 Painted Iron

• EBL-6DS

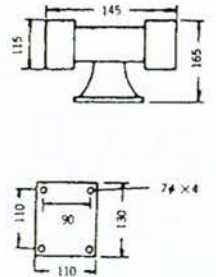

• EBL-7

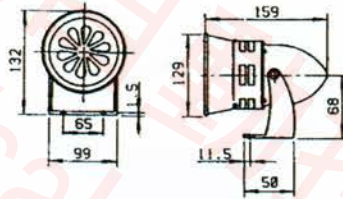

電壓 Voltage	DC12V、DC24V、AC110V、AC220V
功率 Power	10W 120db
尺寸 Size	5"
材質 Material	鋁質電鍍 Plated Aluminum

• EBL-8

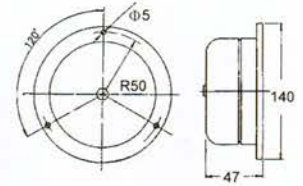

電壓 Voltage	AC110V、AC220V
材質 Material	鋁質烤漆 Painted Aluminum

• MS

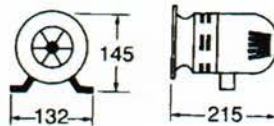

電壓 Voltage	DC12V、DC24V、AC110V、AC220V
功率 Power	30W
尺寸 Size	215x132x145
材質 Material	鋁質烤漆 Painted Aluminum

• EA-50(50W)



• EA-70(50W)



電壓 Voltage	DC12V
功率 Power	50W
電流 Current	7A
功能 Function	汽笛聲 Hooter、消防警 Fire Truck、救護警 Ambulance 警車聲 Squad Car、警報聲 Alarm、麥克風 Micro Phone

• EA-100(70W)



電壓 Voltage	DC12V
功率 Power	70W
電流 Current	10A
功能 Function	汽笛聲 Hooter、消防警 Fire Truck、救護警 Ambulance 警車聲 Squad Car、警報聲 Alarm、麥克風 Micro Phone



Buzzer

型號說明 Model Designation :

$\frac{DZL}{1} - \frac{225}{2} - \frac{1}{3}$



項次	代號	說明		
1. 型式	DZ	蜂鳴器		
	DL	指示燈		
	DZL	指示燈附蜂鳴器		
2. 孔徑	225	Φ22mm、Φ25mm		
	30	Φ30mm		
3. 電壓	1	AC110V	2	AC220V
	7	DC24V	9	DC12V

產品特色：

1. 結合指示燈與蜂鳴器功能，精簡配電盤盤面，一物兩用節省預算。
2. 本產品為22mm、25mm以及30mm通用。(30mm須搭配專用配件)
3. 配線保護蓋使您在使用時安全無虞。
4. 採用高透光塑膠蓋與激光LED燈泡，警示燈號清晰易見。

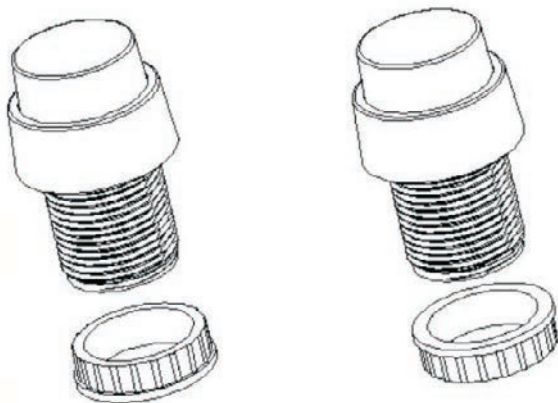

用於22mm孔徑時，請依出廠方向套入固定螺母
用於25mm孔徑時，請依相反方向套入固定螺母

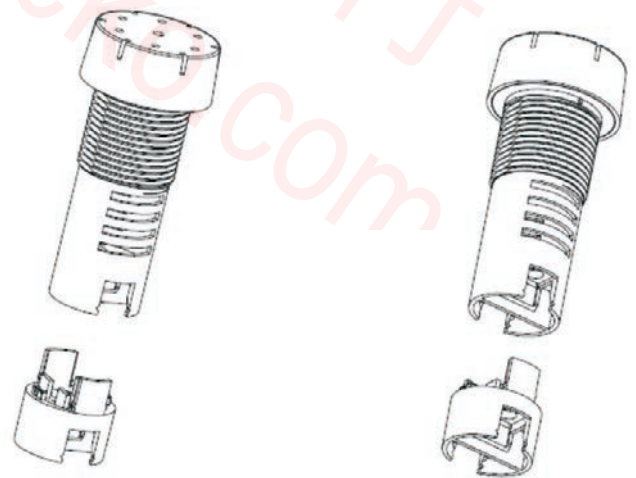

免工具輕鬆拆裝配線保護蓋