

AUSPICIUS

HOIST WATER PROOF PUSH BUTTON SWITCH



2007 - F



HOIST WATER PROOF PUSH BUTTON (INDIRECT OPERATION)



Number of buttons	Complete type	Rating	Cable bushing diameter(mm)
2(1pair)	HS-61	24VAC 5A	8~16Dia
4(2pair)	HS-62	120VAC 5A	
6(3pair)	HS-63	250VAC 5A	
8(4pair)	HS-64	500VAC 5A 24VDC 2A 120VDC 0.4A	

Compact high visibility orange enclosure NEMA 4x enclosure rating
Ultra-long service life , -15° C~70° C operation 100g shock resistance

DIMENSIONS

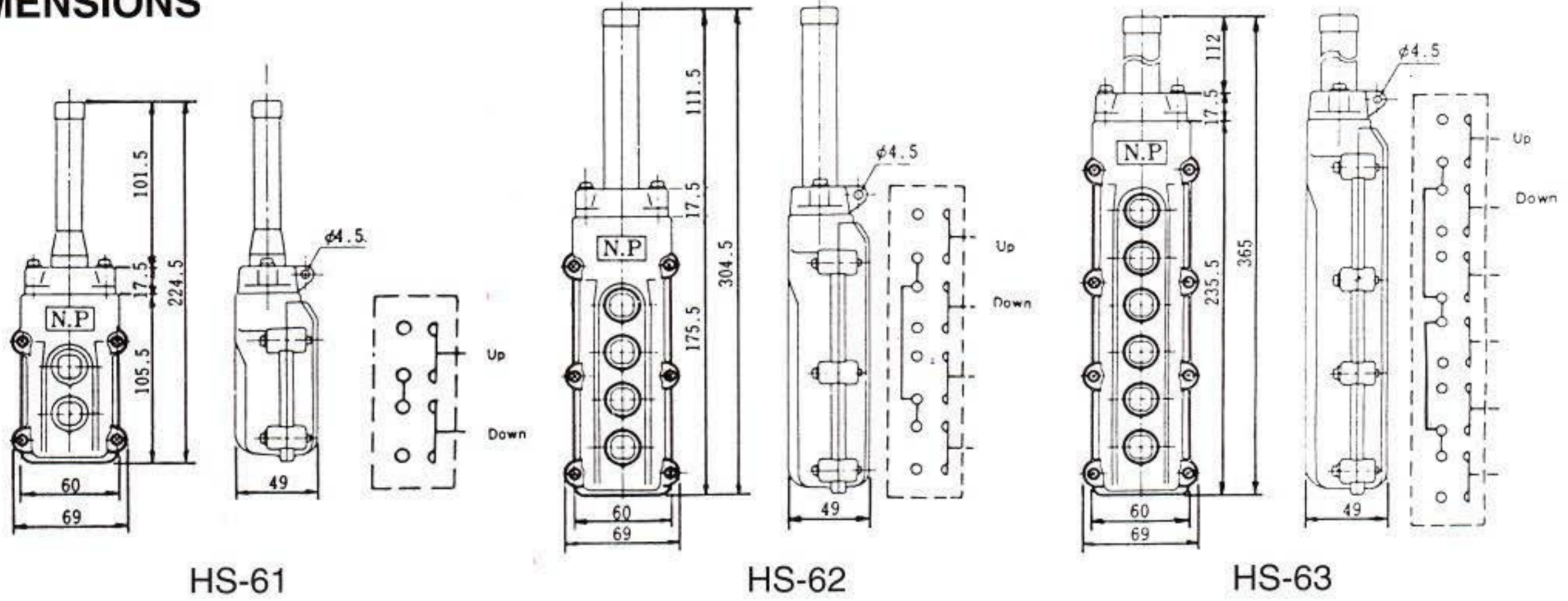

Note:All switch pairs are mechanically interlocked.
ON-OFF can be substituted in first two buttons
any switch shown

LEGENDS

UP	DOWN	FAST	SLOW	HING	LOW	NORTH	SOUTH
ON	OFF	RIGHT	LEFT	RAISE	LOWER	EAST	WEST
IN	OUT	FWD	REV	START	STOP	OPEN	CLOSE

DIRECT OPERATION HOIST PUSH BUTTON PENDANT SWITCH

Dimensions and Connections of COB213



COB213

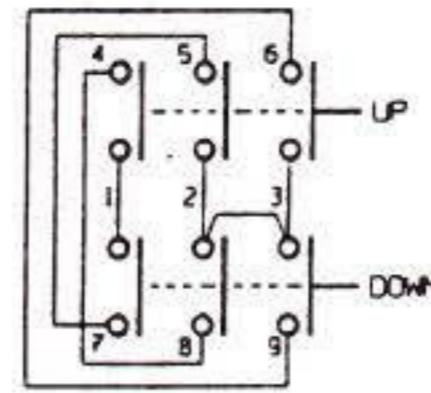
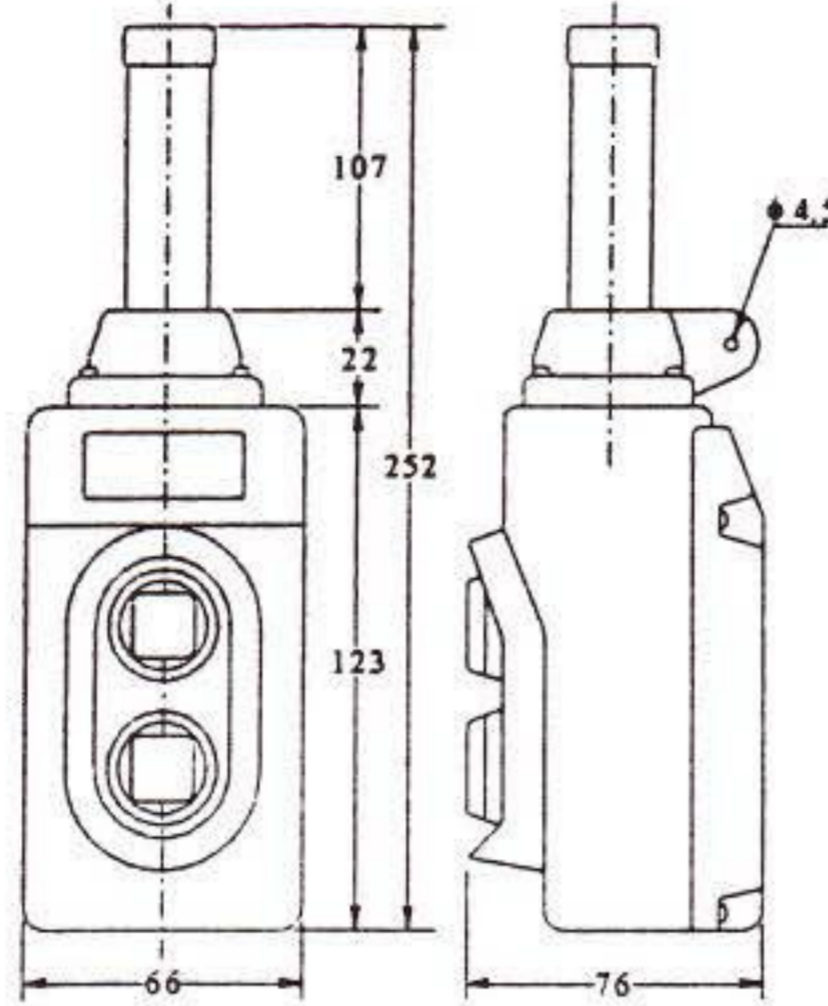

COB 213
 1-3: Power source
 1-6: Main winding
 4-5: Starting winding

Dimensions in mm

Designed for direct control of single phase electric motors. Since motor current is controlled directly by the pendant switch no extra reversing contactors or costly controls are required.

Features

- Durable high quality A.B.S. Pendant switch housing
- Highly visible safety orange color
- NEMA 4 water-proof enclosure
- Split case design for easy installation and wiring
- Flexible cable boot selected to match size of cable prevents entry of foreign debris
- Slim compact size suited for one hand operation
- Control ratings for 1HP max. at 120 VAC
- Two button switch with a wide range of legend markings



COB21
 COB22
 COB23

Legends

UP, DOWN, RAISE, LOWER, EAST, WEST, NORTH, SOUTH, U, D, E, W, N, S, R, L, ↑ ↓

Rating: 220VAC, 2.2KW water proof, direct operation

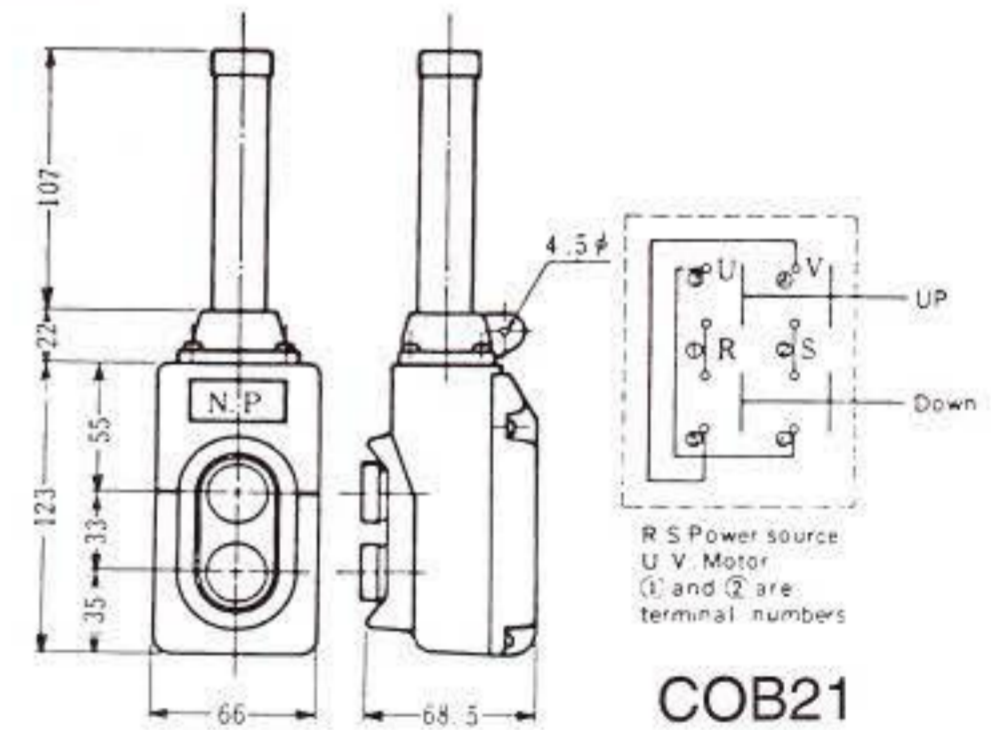

COB21

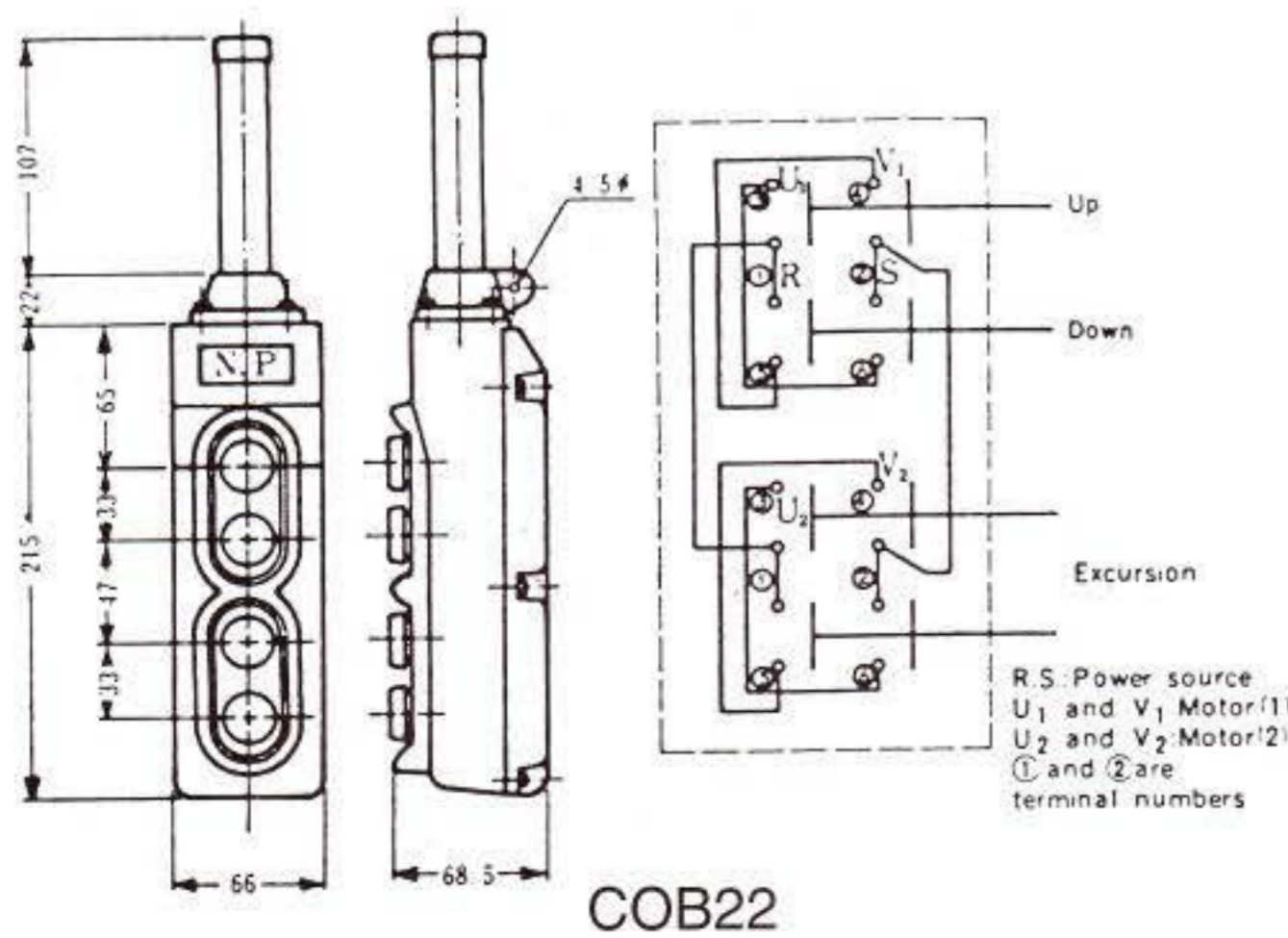

COB22

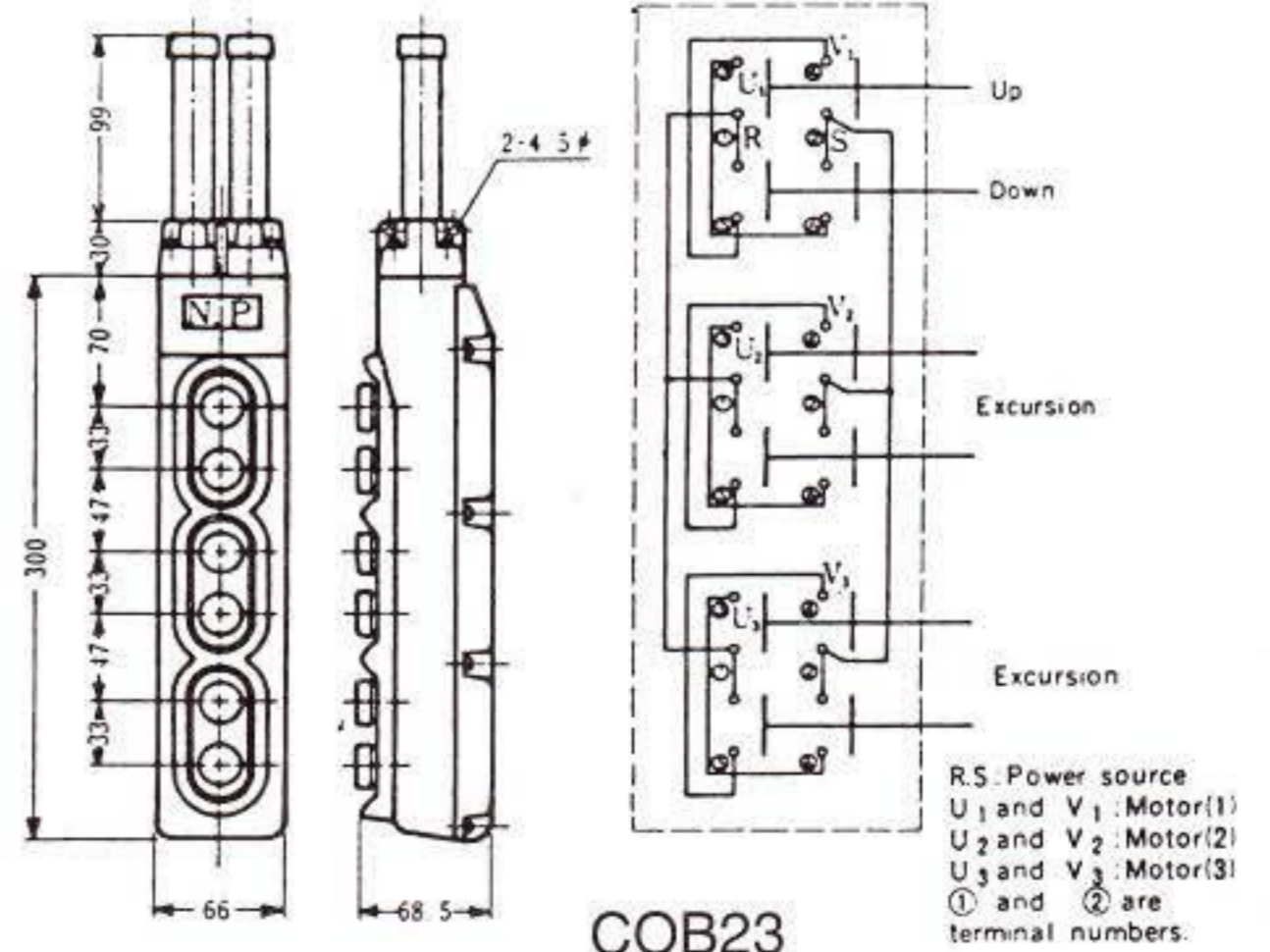

COB23

HOIST WATER PROOF PUSH BUTTON PENDANT SWITCH



HS802

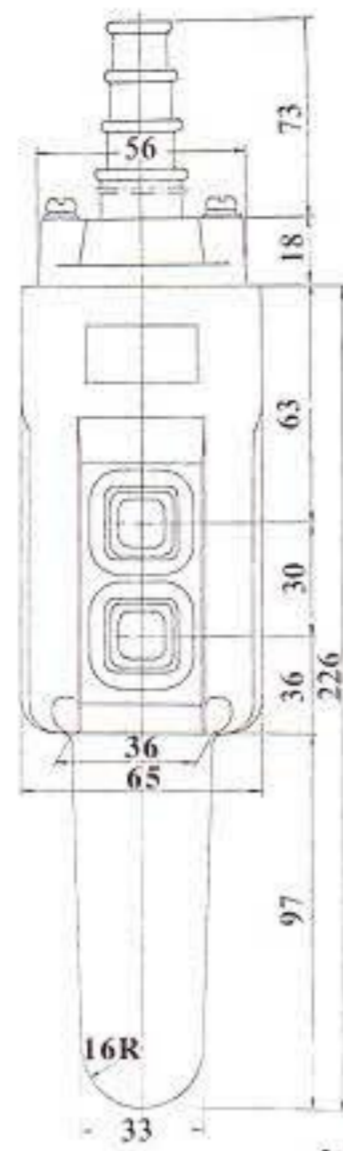

HS802

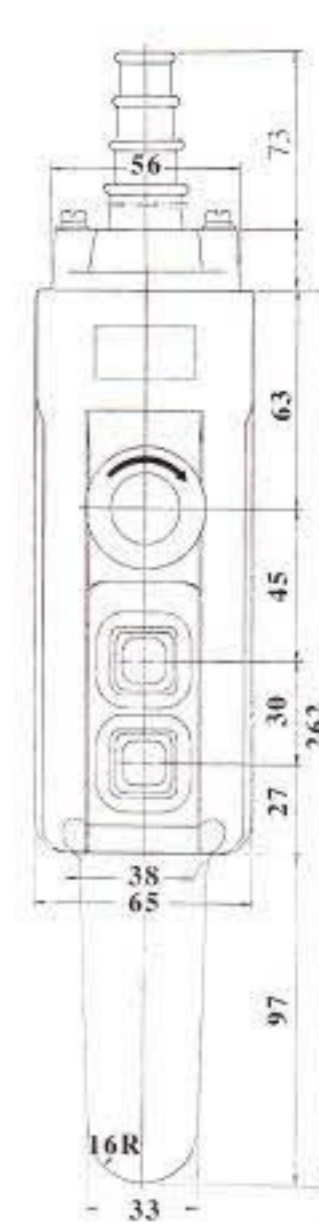
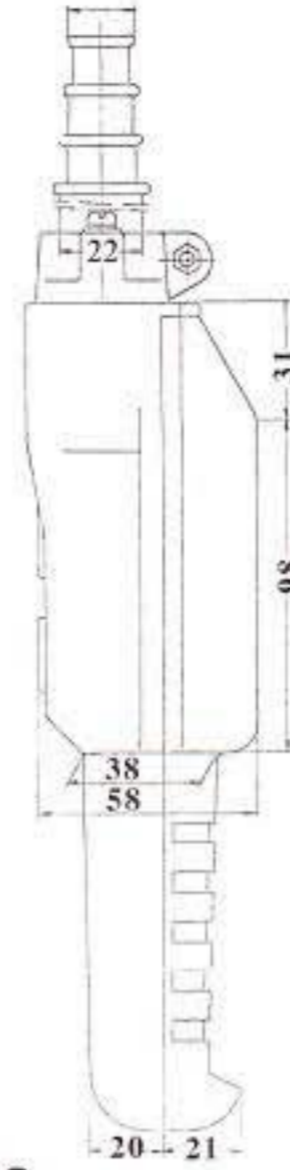

HS803

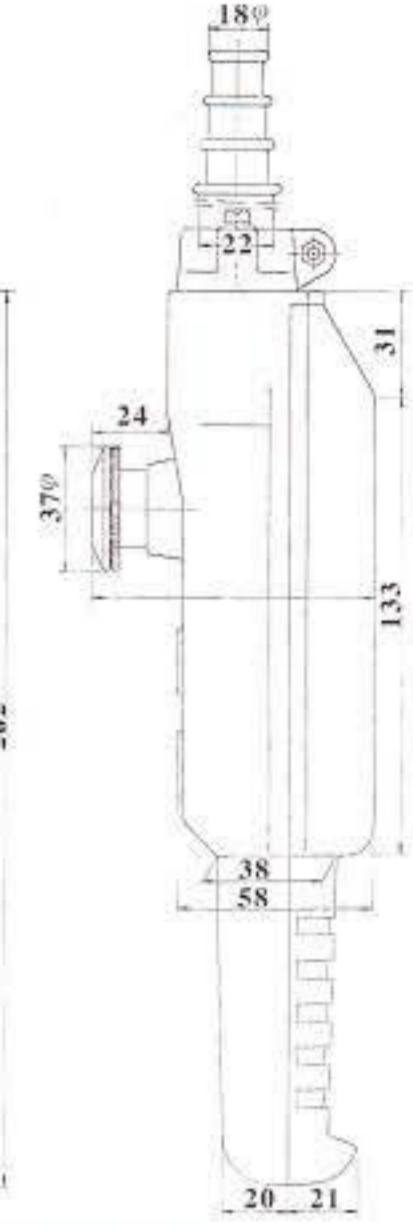

HS803

The **HS80 Series** is a compact, pistol-grip design two-button, three-button with Emergency stop pendant station, and features:

- An especially ergonomic design-less than three inches wide-weighing only 10 ounces
- Construction of high impact ABS, and high visibility safety yellow
- NEMA 4 waterproof rating
- Single-speed 5 amp, 250 volt contact block
- Multi-diameter cable bushing



HS81

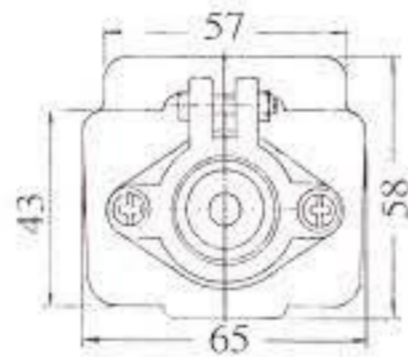

HS81

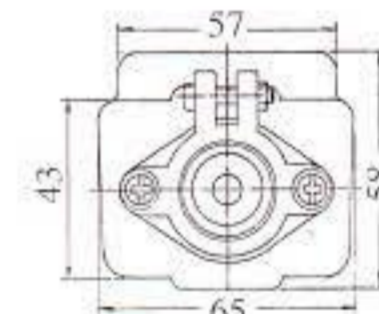
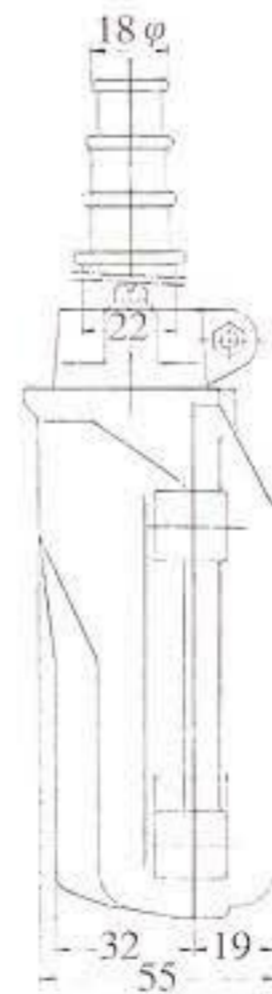
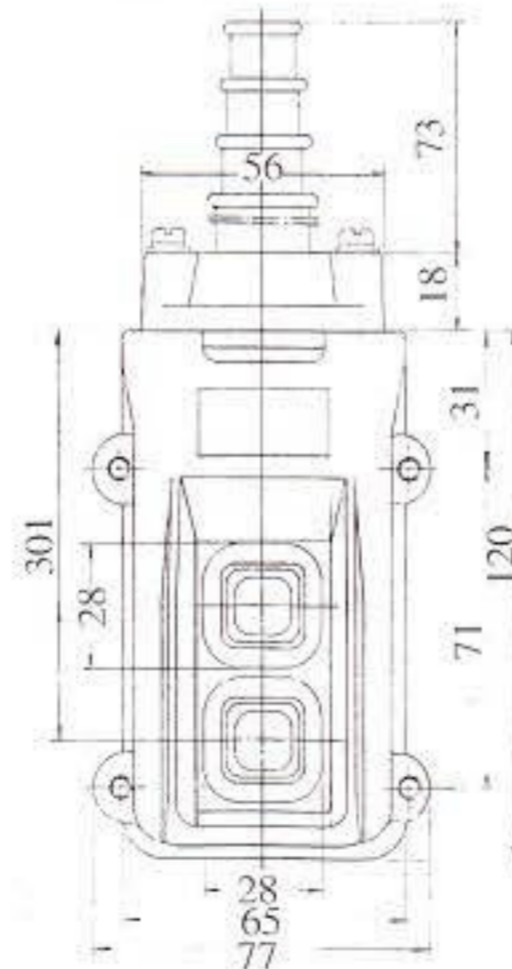

HS82

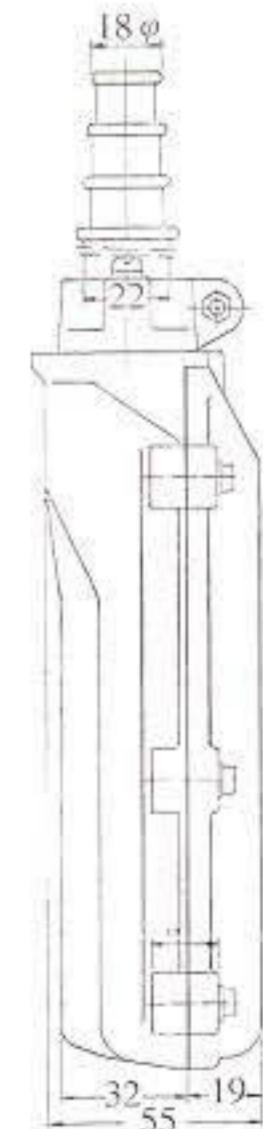
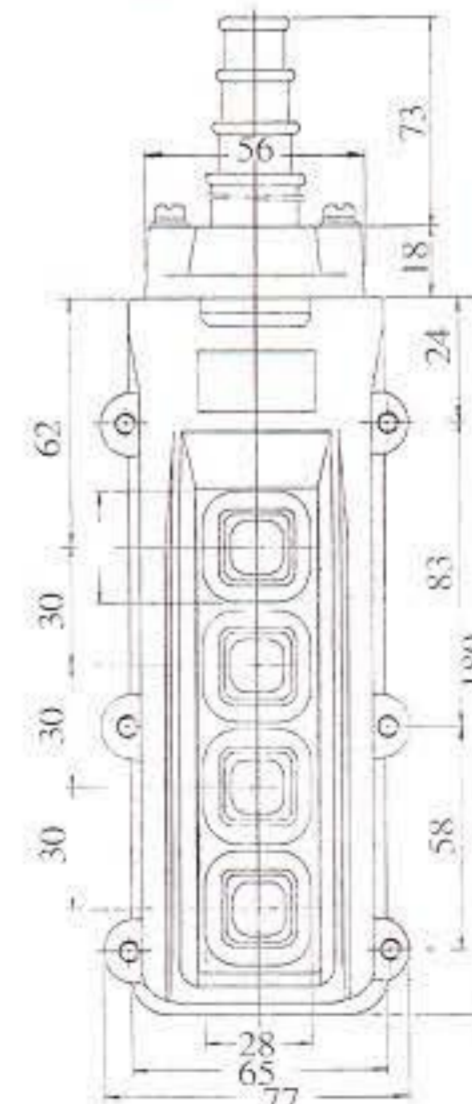

HS82

HOIST WATER PROOF PUSH BUTTON PENDANT SWITCH



ENPROTEKO CO.,LTD.



HS83

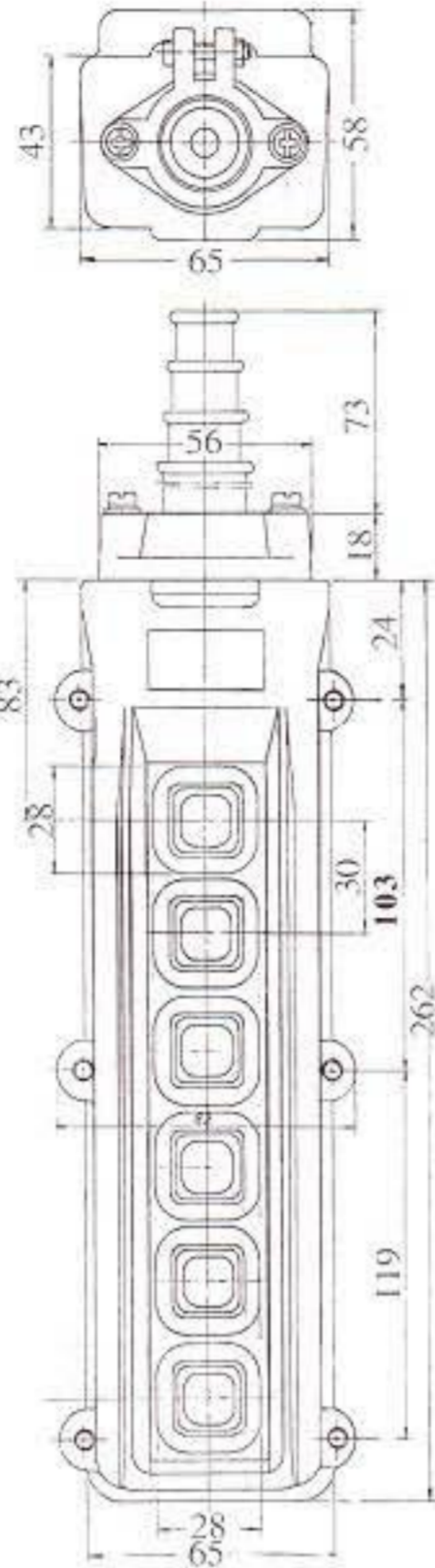

HS83



HS84

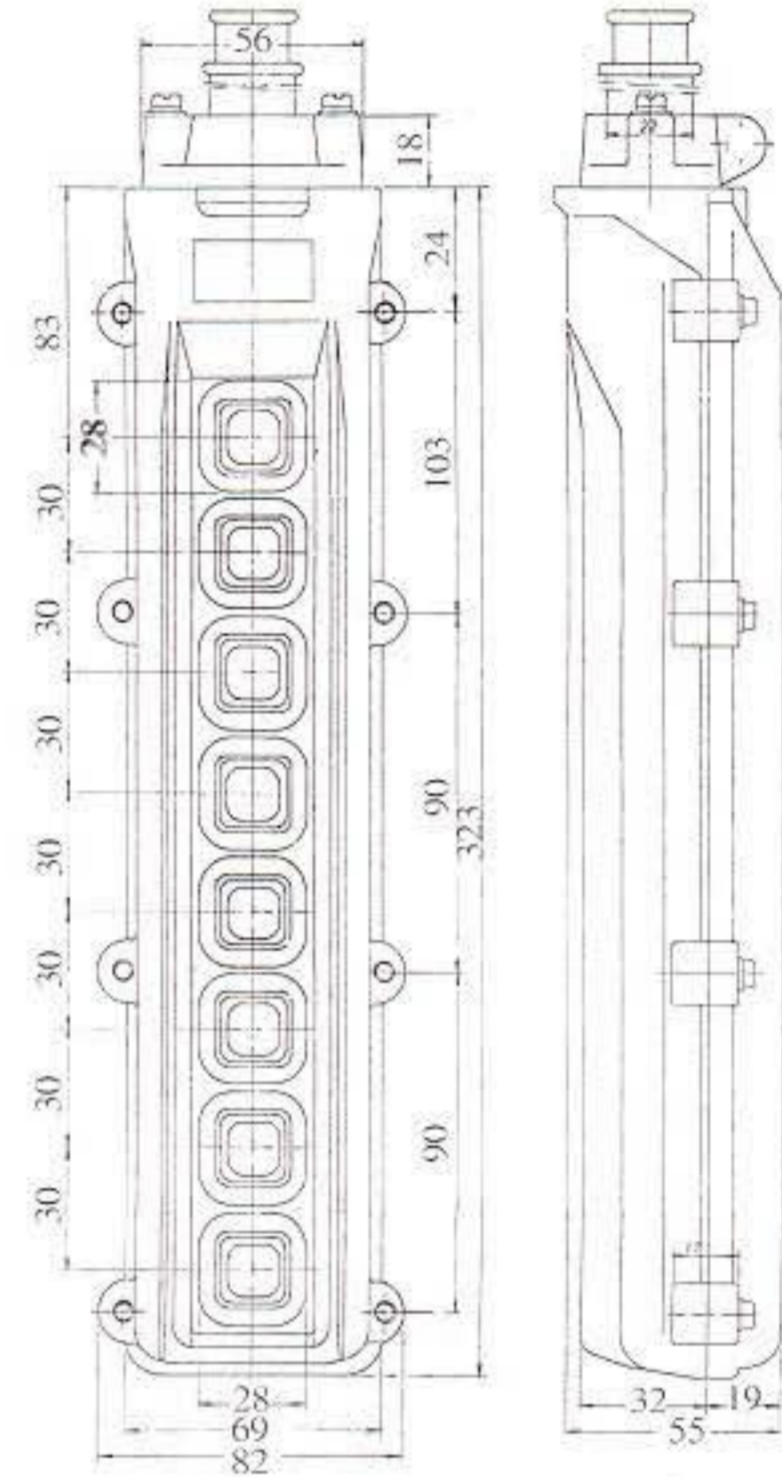

HS84



HS85

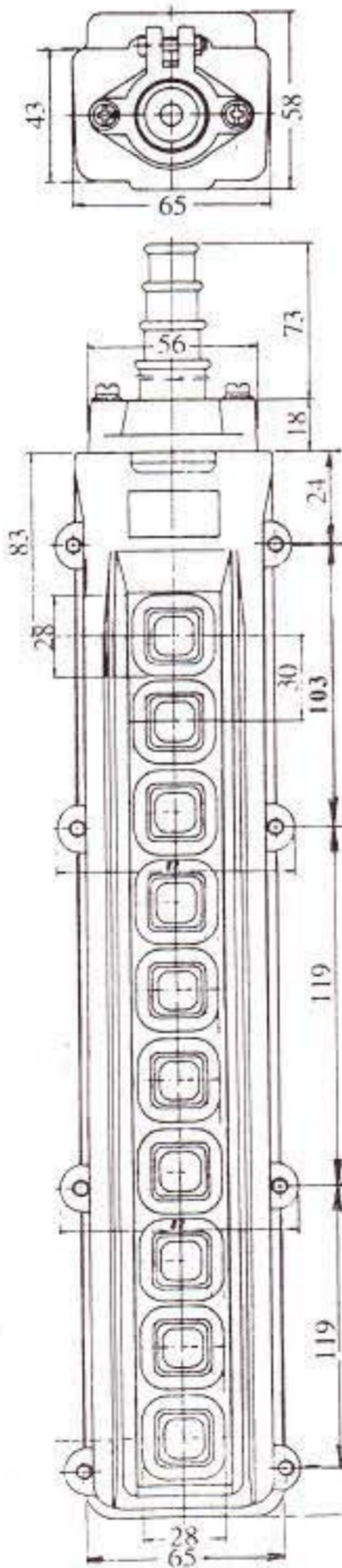

HS85



HS86

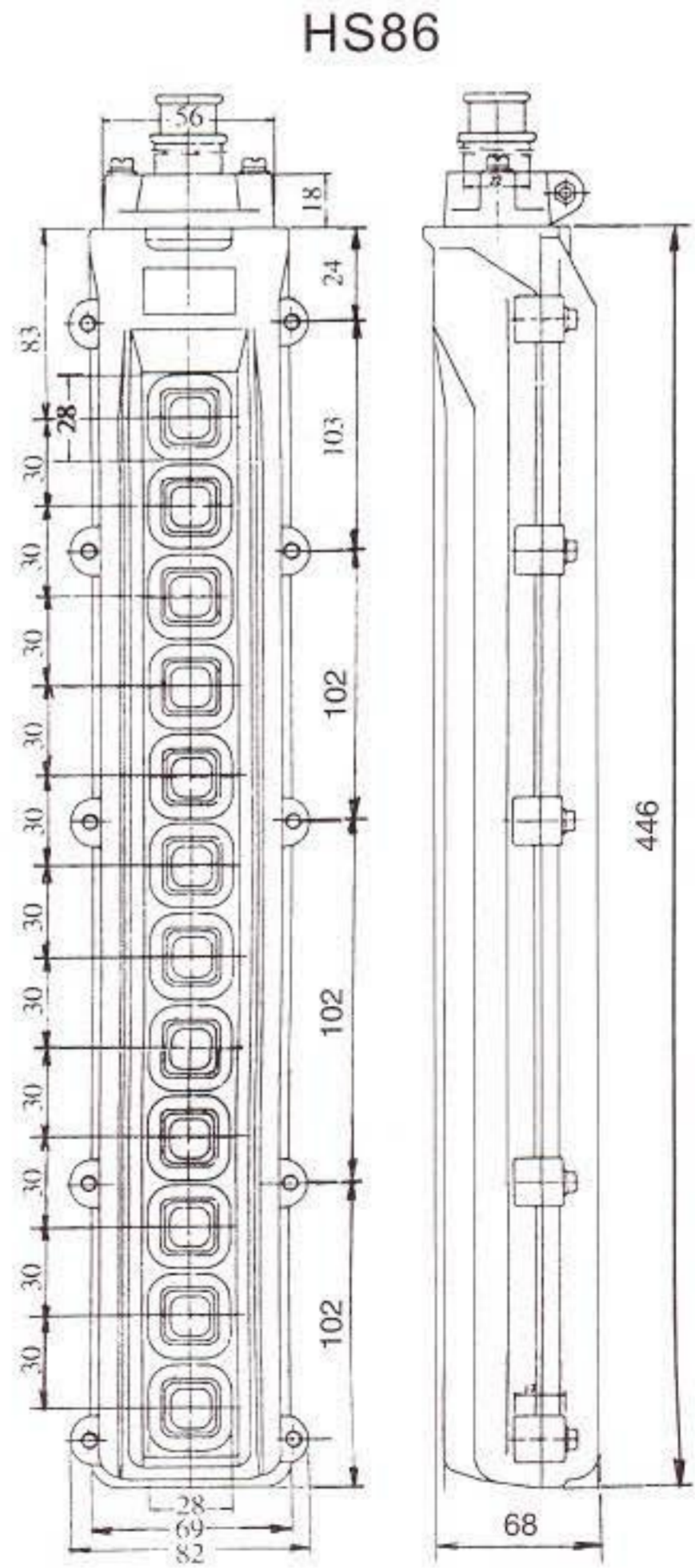

HS86

HOIST WATERPROOF PUSH BUTTON PENDANT SWITCH



HS821

HS822



Item No.

HS821

Emergency stop switch, (Reset)
Illuminated push off -push on switch
2 Single speed UP, Down (↑ . ↓)
Deep back

HS822

Emergency stop switch, (Reset)
Illuminated push off -push on switch
2 Double speed UP, Down (↑↑ . ↓↓)
Deep back

HS831
HS832HS833
HS834

HS831

Emergency stop switch, (Reset)
Selector switch 2 position, 1 - 2
4 Single speed

HS832

Emergency stop switch, (Reset)
Selector switch 2 position, 1 - 2
4 Double speed

HS833

Emergency stop switch, (Reset)
Illuminated push off -push on switch
4 Single speed
Deep back

HS834

Emergency stop switch, (Reset)
Illuminated push off -push on switch
4 Double speed
Deep back

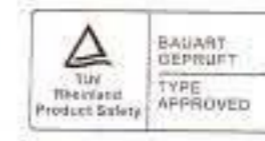
**HOIST WATER PROOF PUSH BUTTON PENDANT SWITCH**HS841
HS842HS843
HS844

Item No.	
HS841	Emergency stop switch, (Reset) Selector switch 2 position, 1 - 2 6 Single speed
HS842	Emergency stop switch, (Reset) Selector switch 2 position, 1 - 2 6 Double speed
HS843	Emergency stop switch, (Reset) Pilot lamp 6 Single speed
HS844	Emergency stop switch, (Reset) Pilot lamp 6 Double speed

HS861
HS862HS851
HS852

HS851	Emergency stop switch, (Reset) Pilot lamp 6 Single speed 2 Double speed
HS852	Emergency stop switch, (Reset) Pilot lamp 4 Single speed 4 Double speed
HS861	Emergency stop switch, (Reset) Selector switch 2 position, 1 - 2 6 Single speed 4 Double speed
HS862	Emergency stop switch, (Reset) Selector switch 2 position, 1 - 2 4 Single speed 6 Double speed