



# 150W四组输出具有PFC功能开关电源 QP-150系列



### ■ 特性:

- 国际通用全范围交流输入
- 内置主动式PFC功能,PF>0.95
- 保护种类: 短路/过负载/过电压
- 内置直流风扇强制风冷
- CH4正负极性可选
- 开关工作频率: 100KHZ
- 3年保固

### 电气规格



型号		QP-150-3A				QP-150-3B				QP-150-3C			
输出	输出通道	CH1	CH2	CH3	CH4	CH1	CH2	CH3	CH4	CH1	CH2	CH3	CH4
	直流电压	5V	3.3V	12V	-5V	5V	3.3V	12V	-12V	5V	3.3V	15V	-15V
	额定电流	10A	10A	5A	0.6A	10A	10A	5A	0.6A	10A	10A	4A	0.6A
	电流范围	3~15A	0~15A	0.4~5A	0~1A	3~15A	0~15A	0.4~5A	0~1A	3~15A	0~15A	0.4~5A	0~1A
	额定功率(最大)	146W				150.2W				152W			
	纹波与噪声(最大)备注2	100mVp-p	100mVp-p	150mVp-p	150mVp-p	100mVp-p	100mVp-p	150mVp-p	150mVp-p	100mVp-p	100mVp-p	150mVp-p	150mVp-p
	电压调整范围	CH1: 4.75~5.5V CH2: 3.14~3.63V				CH1: 4.75~5.5V CH2: 3.14~3.63V				CH1: 4.75~5.5V CH2: 3.14~3.63V			
	电压精度备注3	±3.0%	±3.0%	±6.0%	±5.0%	±3.0%	±3.0%	±6.0%	±5.0%	±3.0%	±3.0%	+8,-6%	±5.0%
	线性调整率	±1.0%	±1.0%	±2.0%	±1.0%	±1.0%	±1.0%	±2.0%	±1.0%	±1.0%	±1.0%	±2.0%	±1.0%
	负载调整率	±2.0%	±2.0%	±6.0%	±2.0%	±2.0%	±2.0%	±6.0%	±2.0%	±2.0%	±2.0%	±6.0%	±2.0%
启动、上升时间	800ms, 50ms/230VAC 800ms, 50ms/115VAC(满载时)												
保持时间(Typ.)	24ms/230VAC 24ms/115VAC(满载时)												
输入	电压范围	90~264VAC或127~370VDC											
	频率范围	47~63Hz											
	功率因素(Typ.)	PF>0.95/230VAC				PF>0.98/115VAC(满载时)							
	效率(Typ.)	73%				75%				74%			
	交流电流(Typ.)	2.5A/115VAC 1.2A/230VAC											
	浪涌电流(Typ.)	冷启动: ≤40A/230VAC											
	漏电流	<3.5mA/240VAC											
保护	过负载	额定输出功率的105%~150% 保护模式:打嗝模式, 负载异常条件移除后可自动恢复											
	过电压	CH1:5.75~6.75V CH2:3.8~4.4V											
	过温度(可选)	95°C±5°C(TSW1) 保护模式:关闭输出电压, 温度下降后可自动恢复											
环境	工作温度	-10~+60°C(请参考负载减额曲线)											
	工作湿度	20~90%RH,无冷凝											
	储存温度、湿度	-20~+85°C, 10~95%RH											
	温度系数	±0.03%/°C(0~50°C)											
	耐振动	10~500Hz, 2G 10分钟/周期, X、Y、Z轴各60分钟											
安规和电磁兼容(备注4)	安全规范	UL60950-1, TUV EN60950-1认证通过											
	耐压	I/P-O/P:3KVAC I/P-FG:1.5KVAC O/P-FG:0.5KVAC											
	绝缘阻抗	I/P-O/P, I/P-FG, O/P-FG:100M Ohms / 500VDC / 25°C / 70% RH											
	电磁干扰	符合EN55022(CISPR22) Class B											
	谐波电流	符合EN61000-3-2, -3											
	电磁耐受	符合EN61000-4-2, 3, 4, 5, 6, 8, 11; ENV50204, EN55024, A级轻工业标准											
其它	MTBF	≥141.5K hrs. MIL-HDBK-217F(25°C)											
	尺寸	199*99*50mm(L*W*H)											
	包装	0.93Kg; 20pcs/19.6Kg/1.28CUFT											
备注	<ol style="list-style-type: none"> <li>1. 如未特别说明, 所有规格参数均在输入为230VAC、额定负载、25°C环境温度下进行量测。</li> <li>2. 纹波和噪声测量方法: 使用一条12"双绞线, 同时终端要并联0.1uf和47uf的电容, 在20MHZ带宽下进行量测。</li> <li>3. 精度: 包含设定误差、线性调整率和负载调整率。</li> <li>4. 电源被视为系统内元件的一部分, 需结合终端设备进行电磁兼容相关确认。 EMC测试方法的指引, 请参照明纬公司网站<a href="http://www.meanwell.com.cn">http://www.meanwell.com.cn</a>上的“EMI测试声明书”。</li> </ol>												



# 150W四组输出具有PFC功能开关电源 QP-150系列



### ■ 特性:

- 国际通用全范围交流输入
- 内置主动式PFC功能,PF>0.95
- 保护种类: 短路/过负载/过电压/过温度
- 内置直流风扇强制风冷
- CH4正负极性可选
- 开关工作频率: 100KHZ
- 3年保固

### 电气规格



型号		QP-150-3D				QP-150D				QP-150F			
输出	输出通道	CH1	CH2	CH3	CH4	CH1	CH2	CH3	CH4	CH1	CH2	CH3	CH4
	直流电压	5V	3.3V	24V	-12V	5V	12V	24V	-12V	5V	15V	24V	-15V
	额定电流	10A	10A	2.5A	0.6A	10A	4A	2A	0.6A	10A	3A	2A	0.6A
	电流范围	3~15A	0~15A	0.3~3A	0~1A	3~15A	0~5A	0.4~3A	0~1A	3~15A	0~5A	0.4~3A	0~1A
	额定功率(最大)	150.2W				150.2W				152W			
	纹波与噪声(最大)备注2	100mVp-p	100mVp-p	150mVp-p	150mVp-p	120mVp-p	150mVp-p	200mVp-p	150mVp-p	120mVp-p	150mVp-p	200mVp-p	150mVp-p
	电压调整范围	CH1: 4.75~5.5V CH2: 3.14~3.63V				CH1: 4.75~5.5V CH2: 11.4~13.2V				CH1: 4.75~5.5V CH2: 14.3~16.5V			
	电压精度备注3	±3.0%	±3.0%	±6.0%	±5.0%	±3.0%	±3.0%	±6.0%	±5.0%	±3.0%	±3.0%	±6.0%	±5.0%
	线性调整率	±1.0%	±1.0%	±2.0%	±1.0%	±1.0%	±1.0%	±2.0%	±1.0%	±1.0%	±1.0%	±2.0%	±1.0%
	负载调整率	±2.0%	±2.0%	±6.0%	±2.0%	±2.0%	±2.0%	±6.0%	±2.0%	±2.0%	±2.0%	±6.0%	±2.0%
启动、上升时间	800ms, 50ms/230VAC 800ms, 50ms/115VAC(满载时)												
保持时间(Typ.)	24ms/230VAC 24ms/115VAC(满载时)												
输入	电压范围备注5	90~264VAC或127~370VDC											
	频率范围	47~63Hz											
	功率因素(Typ.)	PF>0.95/230VAC				PF>0.98/115VAC(满载时)							
	效率(Typ.)	76%				78%				78%			
	交流电流(Typ.)	2.5A/115VAC 1.2A/230VAC											
	浪涌电流(Typ.)	冷启动: ≤40A/230VAC											
	漏电流	<3.5mA/240VAC											
保护	过负载	额定输出功率的105%~150% 保护模式:打嗝模式, 负载异常条件移除后可自动恢复											
	过电压	CH1:5.75~6.75V CH2:3.8~4.4V				CH1:5.75~6.75V CH2:13.8~16.2V				CH1:5.75~6.75V CH2:17.25~20.25V			
	过温度(可选)	95°C±5°C(TSW1) 保护模式:关闭输出电压, 温度下降后可自动恢复											
环境	工作温度	-10~+60°C(请参考负载减额曲线)											
	工作湿度	20~90%RH,无冷凝											
	储存温度、湿度	-20~+85°C, 10~95%RH											
	温度系数	±0.03%/°C(0~50°C)											
	耐振动	10~500Hz, 2G 10分钟/周期, X、Y、Z轴各60分钟											
安规和电磁兼容(备注4)	安全规范	UL60950-1, TUV EN60950-1认证通过											
	耐压	I/P-O/P:3KVAC I/P-FG:1.5KVAC O/P-FG:0.5KVAC											
	绝缘阻抗	I/P-O/P, I/P-FG, O/P-FG:100M Ohms / 500VDC / 25°C / 70% RH											
	电磁干扰	符合EN55022(CISPR22) Class B											
	谐波电流	符合EN61000-3-2, -3											
	电磁耐受	符合EN61000-4-2, 3, 4, 5, 6, 8, 11; ENV50204, EN55024, A级轻工业标准											
其它	MTBF	≥141.5K hrs. MIL-HDBK-217F(25°C)											
	尺寸	199*99*50mm(L*W*H)											
	包装	0.93Kg; 20pcs/19.6Kg/1.28CUFT											
备注	<ol style="list-style-type: none"> <li>1. 如未特别说明, 所有规格参数均在输入为230VAC、额定负载、25°C环境温度下进行量测。</li> <li>2. 纹波和噪声测量方法: 使用一条12"双绞线, 同时终端要并联0.1uf和47uf的电容, 在20MHZ带宽下进行量测。</li> <li>3. 精度: 包含设定误差、线性调整率和负载调整率。</li> <li>4. 电源被视为系统内元件的一部分, 需结合终端设备进行电磁兼容相关确认。 EMC测试方法的指引, 请参照纬科公司网站<a href="http://www.meanwell.com.cn">http://www.meanwell.com.cn</a>上的“EMI测试声明书”。</li> </ol>												



# 150W四组输出具有PFC功能开关电源 QP-150系列

## ■ 机构尺寸

机壳型号:916B 单位:mm

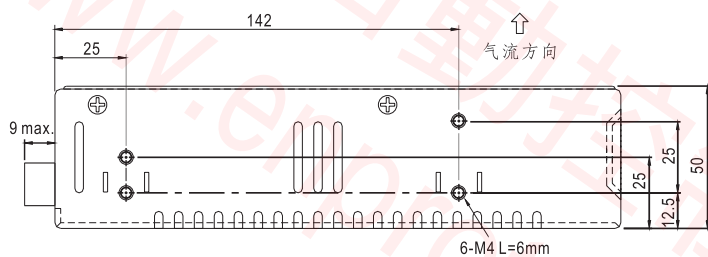
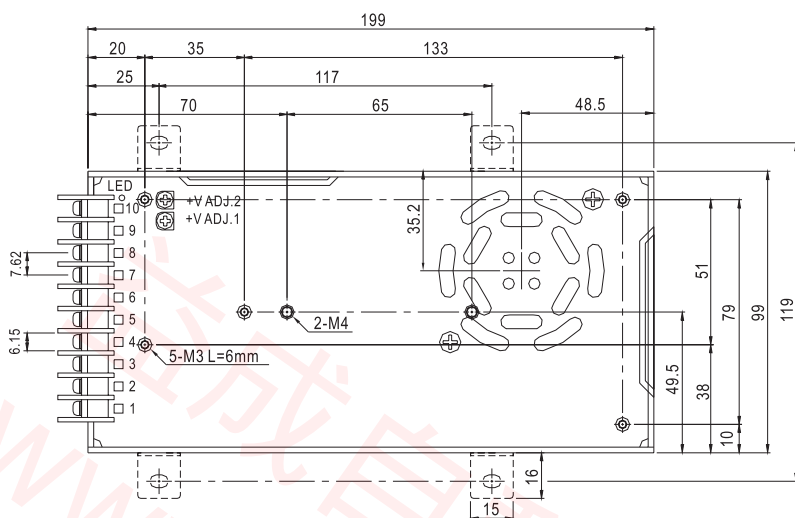

端子台脚位定义

引脚编号	引脚功能	引脚编号	引脚功能
1	AC/L	5	DC OUTPUT V3
2	AC/N	6,7	DC OUTPUT V1
3	FG 地	8,9	DC OUTPUT COM
4	DC OUTPUT V4	10	DC OUTPUT V2

## ■ 方框图

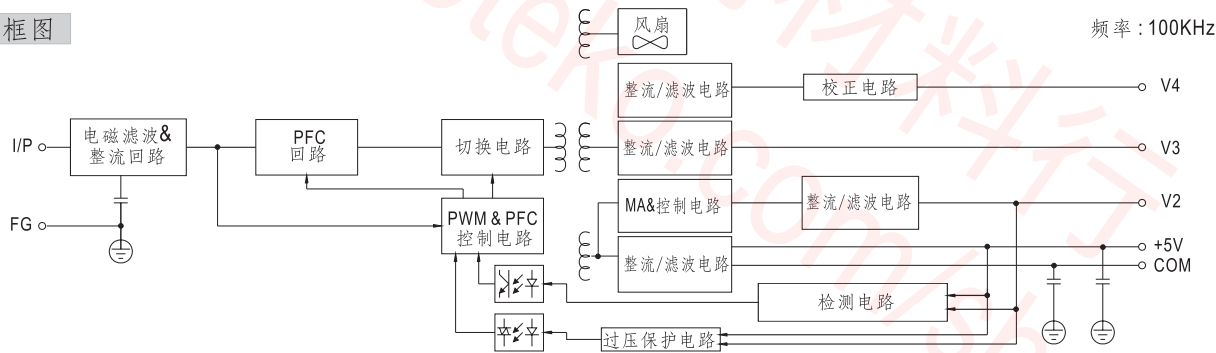

## ■ 负载减额曲线

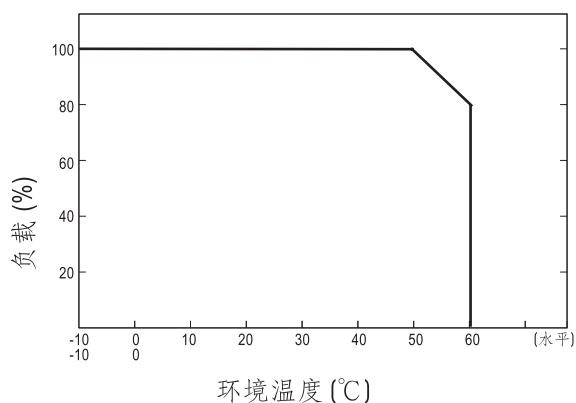

## ■ 静态特性曲线

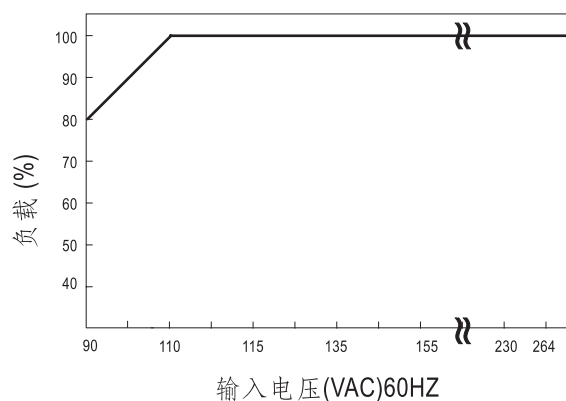



# 150W四组输出具有PFC功能电源

# QP-150B,C系列



### ■ 特性:

- 国际通用全范围交流输入
- 内置主动式PFC功能,PF>0.95
- 保护种类: 短路/过负载/过电压/过温度
- 内置直流风扇强制风冷
- 开关工作频率: 100KHZ
- 3年保固

### 电气规格



型号		QP-150B				QP-150C			
输出	输出通道	CH1	CH2	CH3	CH4	CH1	CH2	CH3	CH4
	直流电压	5V	12V	-12V	-5V	5V	15V	-15V	-5V
	额定电流	15A	4A	2A	0.6A	15A	3A	2A	0.6A
	电流范围	3 ~ 15A	0.4 ~ 5A	0.3 ~ 2A	0 ~ 1A	3 ~ 15A	0.4 ~ 4A	0.3 ~ 2A	0 ~ 1A
	额定功率(最大)	150W				153W			
	纹波与噪声(最大)备注2	100mVp-p	150mVp-p	150mVp-p	100mVp-p	100mVp-p	150mVp-p	150mVp-p	100mVp-p
	电压调整范围	CH1:4.75 ~ 5.5V				CH1:4.75 ~ 5.5V			
	电压精度备注3	±3.0%	±6.0%	+10,-6%	±5.0%	±3.0%	+6,-10%	±8.0%	±5.0%
	线性调整率	±1.0%	±2.0%	±2.0%	±1.0%	±1.0%	±2.0%	±2.0%	±1.0%
	负载调整率	±2.0%	±6.0%	±6.0%	±2.0%	±2.0%	±6.0%	±6.0%	±2.0%
启动、上升时间	1000ms, 50ms(满载时)								
保持时间(Typ.)	24ms(满载时)								
输入	电压范围	90 ~ 264VAC或127 ~ 370VDC							
	频率范围	47 ~ 63Hz							
	功率因素(Typ.)	PF>0.95/230VAC				PF>0.98/115VAC			
	效率(Typ.)	76%				77%			
	交流电流(Typ.)	2.5A/115VAC		1.2A/230VAC					
	浪涌电流(Typ.)	冷启动: ≤40A							
	漏电流	<3.5mA / 240VAC							
保护	过负载	额定输出功率的105%~135% 保护模式:打嗝模式, 负载异常条件移除后可自动恢复							
	过电压	CH1:5.75 ~ 6.75V 保护模式:关闭输出电压,重启后恢复							
	过温度(可选)	95°C ±5°C (TSW1) 保护模式:关闭输出电压, 温度下降后可自动恢复							
环境	工作温度	-10~+60°C (请参考负载减额曲线)							
	工作湿度	20 ~ 90% RH,无冷凝							
	储存温度、湿度	-20 ~ +85°C, 10 ~ 95% RH							
	温度系数	±0.03%/°C (0 ~ 50°C)							
	耐振动	10 ~ 500Hz, 2G 10分钟/周期, X、Y、Z轴各60分钟							
安规和电磁兼容(备注4)	安全规范	UL60950-1,TUV EN60950-1认证通过							
	耐压	I/P-O/P:3KVAC I/P-FG:1.5KVAC O/P-FG:0.5KVAC							
	绝缘阻抗	I/P-O/P, I/P-FG, O/P-FG:100M Ohms / 500VDC / 25°C / 70% RH							
	电磁干扰	符合EN55022 (CISPR22) Class B							
	谐波电流	符合EN61000-3-2,-3							
	电磁耐受	符合EN61000-4-2,3,4,5,6,8,11;ENV50204,EN55024,A级轻工业标准							
其它	MTBF	≥141.5K hrs. MIL-HDBK-217F (25°C)							
	尺寸	199*99*50mm (L*W*H)							
	包装	1.1Kg; 20pcs/22Kg/1.28CUFT							
备注	1. 如未特别说明, 所有规格参数均在输入为230VAC、额定负载、25°C环境温度下进行量测。 2. 纹波和噪声测量方法: 使用一条12"双绞线, 同时终端要并联0.1uf和47uf的电容, 在20MHZ带宽下进行量测。 3. 精度: 包含设定误差、线性调整率和负载调整率。 4. 电源被视为系统内元件的一部分, 需结合终端设备进行电磁兼容相关确认。 EMC测试方法的指引, 请参照明纬公司网站 <a href="http://www.meanwell.com.cn">http://www.meanwell.com.cn</a> 上的“EMI测试声明书”。								



# 150W四组输出具有PFC功能电源

# QP-150B,C系列

## ■ 机构尺寸

机壳型号:916B 单位:mm

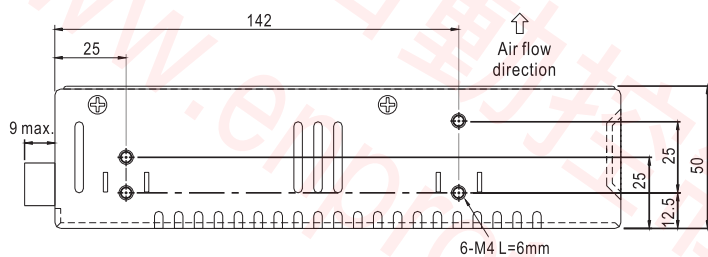
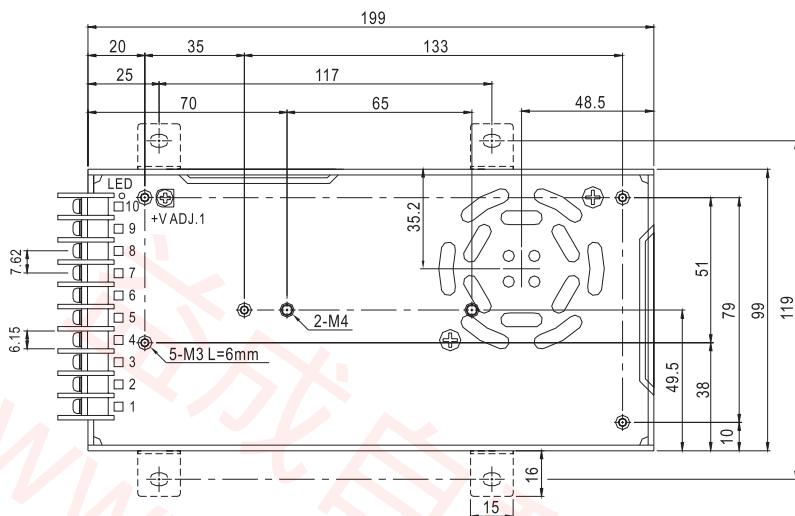

端子台脚位定义

引脚编号	引脚功能	引脚编号	引脚功能
1	AC/L	5	DC OUTPUT V3
2	AC/N	6,7	DC OUTPUT V1
3	FG 地	8,9	DC OUTPUT COM
4	DC OUTPUT V4	10	DC OUTPUT V2

## ■ 方框图

频率: 100KHz

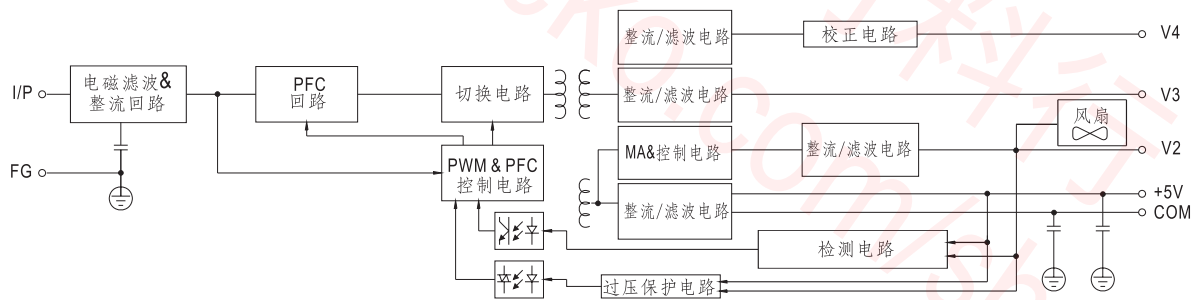

## ■ 负载减额曲线

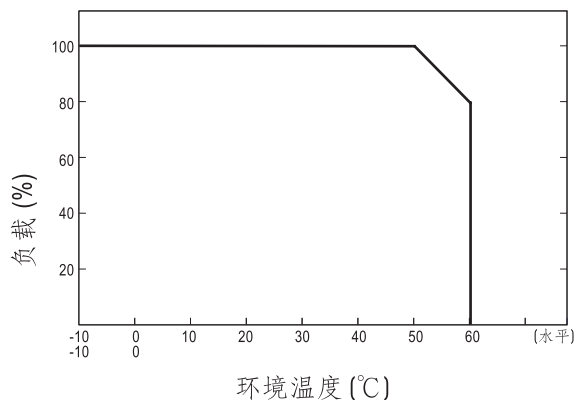

## ■ 静态特性曲线

