

# 多段式切換開關 / CAM SWITCHES

型號說明：  
Model Designation

# NCS-S6C241A101

1                      2                      3                      4                      5

### 1. 型式 (Type)

S6	Normal Shaft 短柄 (64x64)	K7	With Key 附鎖 (76x76)
S8	Normal Shaft 短柄 (64x80)	P5	Circle Shaft 圓柄 (65x65)
L6	Long Shaft 長柄 (64x64)	S5	Normal Shaft 短柄 (65x65)
L8	Long Shaft 長柄 (64x80)	L5	Long Shaft 長柄 (65x65)
O6	Octangle Shaft 八角柄 (64x64)	S4	Normal Shaft 短柄 (48x48)
O8	Octangle Shaft 八角柄 (64x80)	M6	Normal Shaft 短柄 (48x60)

### 2. 位置與角度 (Position & Degrees)

C241 ~ C843
V491 ~ V496
V841 ~ V843
A491 ~ A496
K241 ~ K843
P261 ~ P661
S261 ~ S844

### 3. 容量 (Capacity)

A	10A
B	16A
C	25A
D	32A

### 4. 線路圖 (Circuit)

101 ~ 607
A33 ~ A34
V33 ~ V35

### 5. 動作 (Movement)

空白 none	標準型 Normal
R	復歸型 45° Spring Return 45°
2	2CT
3	3CT

### 容量 (Capacity):

	AC-3 (kw)		AC-21A Iu=Ith	AC-23A (kw)	
	3PH	1PH		3PH	1PH
200~240V	1.5	0.55	10A	1.8	0.75
380~440V	2.2	0.75		3	1.1
660~690V	3	0.75		3	1.1
200~240V	3	1.5	16A	4	2.2
380~440V	5.5	2.2		7.5	3
660~690V	5.5	2.2		7.5	3
200~240V	4	3	25A	5.5	3
380~440V	7.5	3.7		11	5.5
660~690V	7.5	3.7		11	5.5
200~240V	5.5	4	32A	7.5	4
380~440V	11	5.5		15	7.5
660~690V	11	5.5		15	7.5

(IEC 60947-3, EN 60947-4-1)

固定孔尺寸 (Caliber Dimensions) :

單位 (Unit) : (mm)

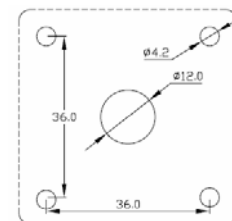
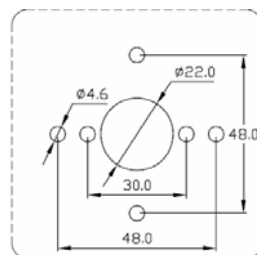
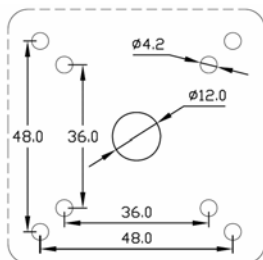

適用型式：  
(For Type)      S6, S8, L6, L8, O6  
                         O8, S5, L5, P5

K7

S4

面板尺寸(Frame Dimensions) :

單位(Unit) : (mm)

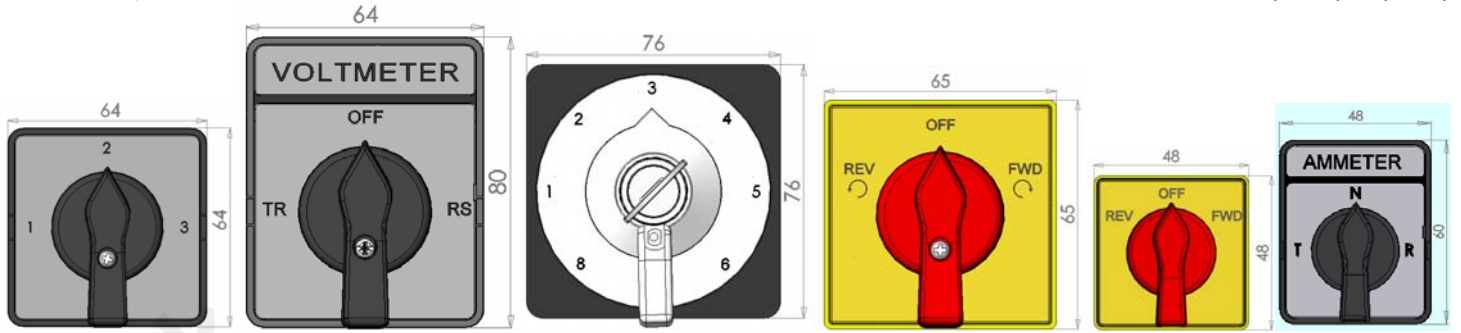

操作位置(Operating Position) :

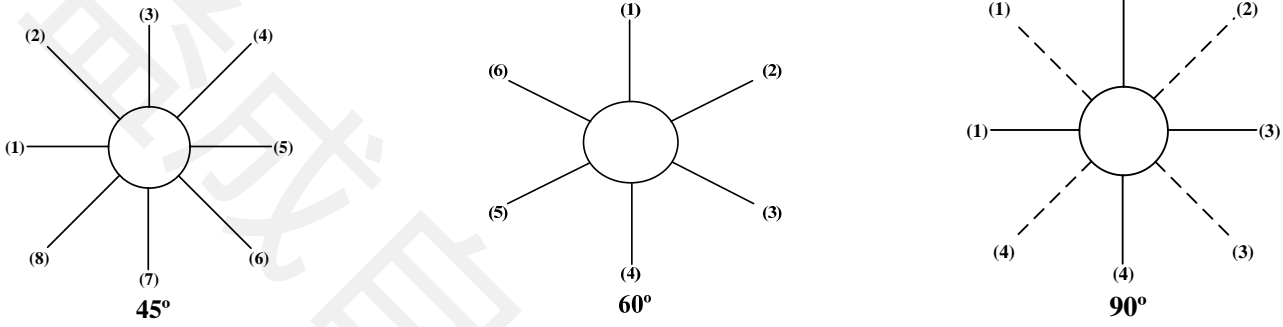

S4,S6,S8,L6,L8,O6,O8,K7,M6

S4,S5,L5

S4,S5,L5,P5,S6,S8,L6,L8,O6,O8,K7,M6

外觀尺寸(Dimensions) :

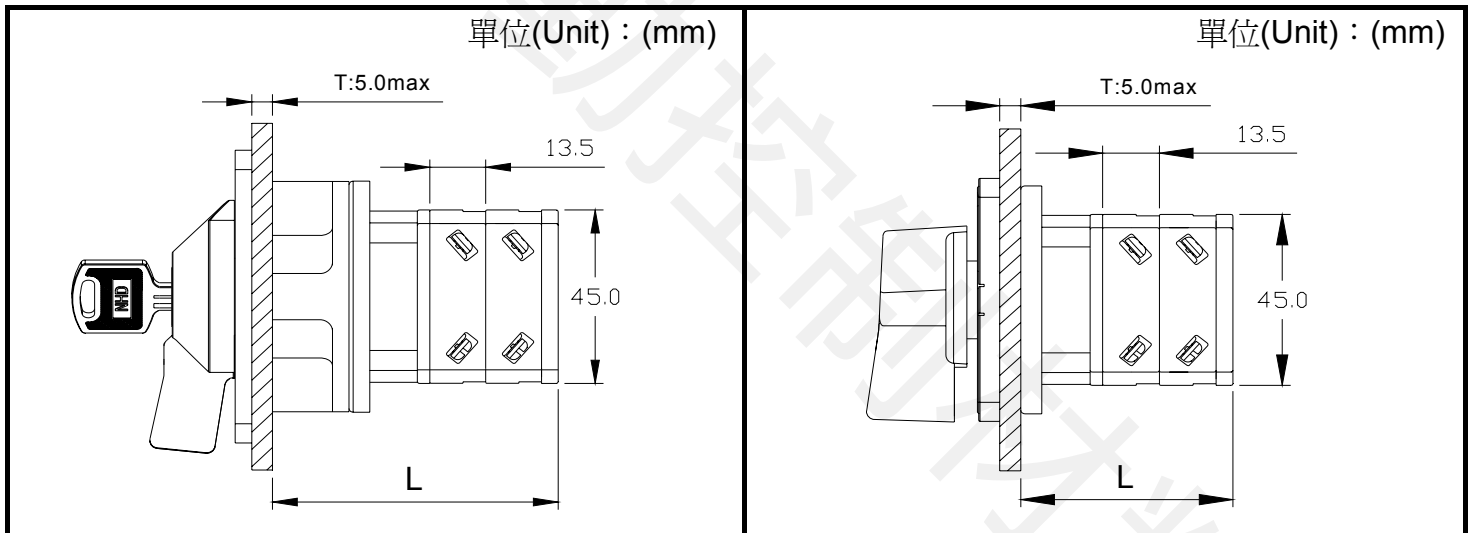

層數 tier	1	2	3	4	5	6	7	8	層數 tier	1	2	3	4	5	6	7	8
L	55.5	69	82.5	96	109.5	123	146.5	160	L	37	50.5	64	77.5	91	104.5	118	131.5

連接圖(Connecting Diagram):

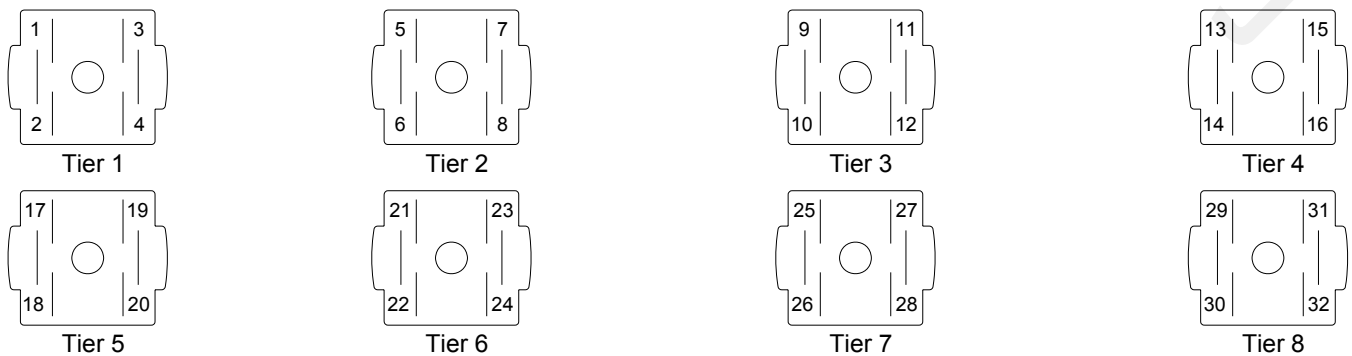

电压切换开关/Voltmeter Switches:

48x60	64x80	64x64	76x76	V33 3Ø3W
V497	V493	V492	V491	OFF RS ST TR
V498	V496	V495	V494	RN RS ST TR
V742	V843	V842	V841	OFF RN SN TN OFF RS ST TR
	V741			RT ST RS OFFRN SN TN

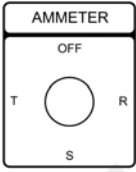
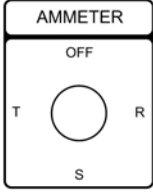
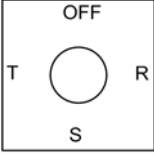
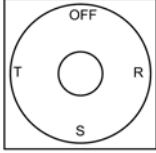
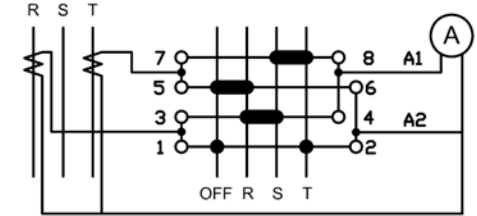
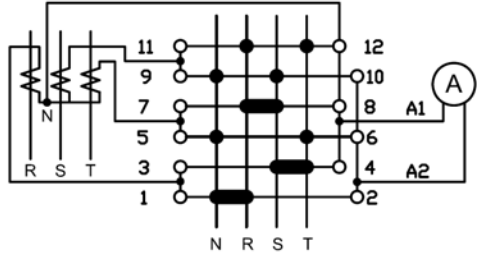
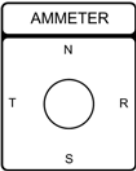
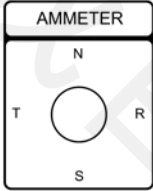
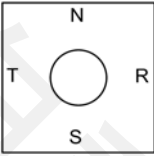
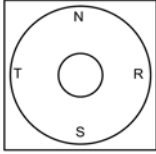
48x60	64x80	64x64	76x76	A33 3Ø3W/2CT
				<p>A33 3Ø3W/2CT</p> 
A497	A493	A492	A491	<p>A34 3Ø4W/3CT</p> 
				
A498	A496	A495	A494	

銘板編號(Name Plate No.) : NCS-S6C241

64x64mm

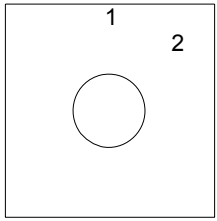

C241

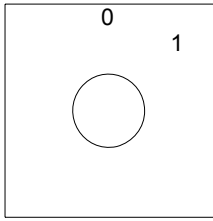

C242

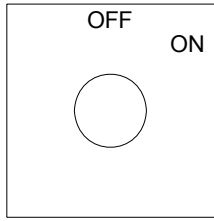

C243

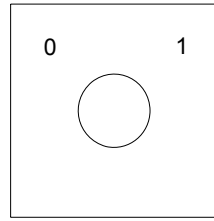

C291

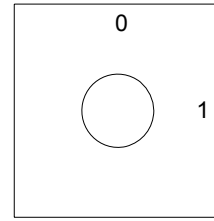

C292

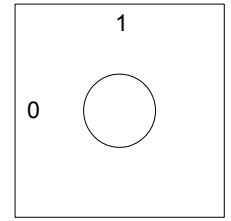

C293

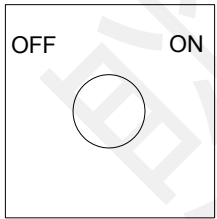

C294

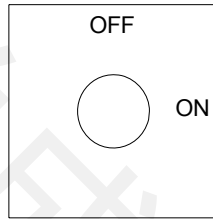

C295

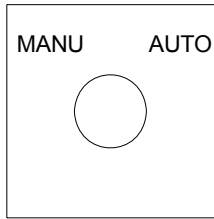

C296

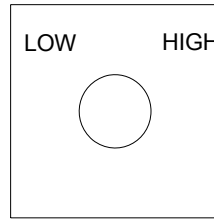

C297

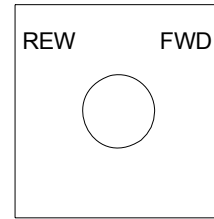

C298

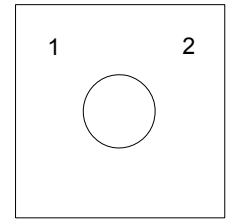

C299

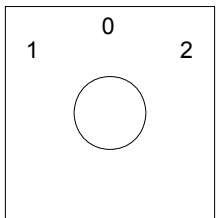

C341

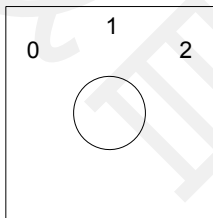

C342

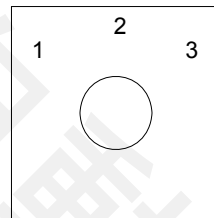

C343

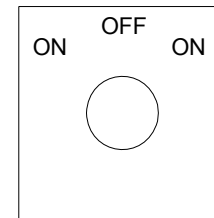

C344

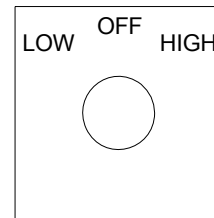

C345

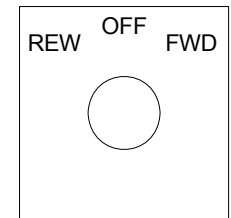

C346

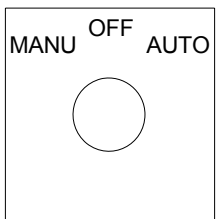

C347

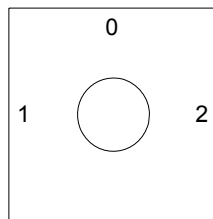

C391

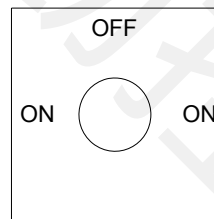

C392

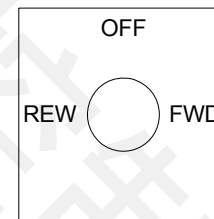

C393

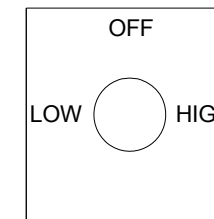

C394

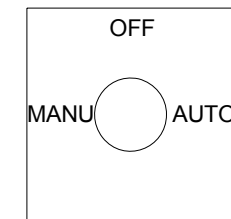

C395

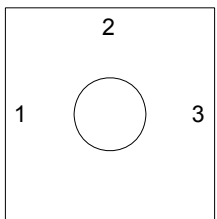

C396

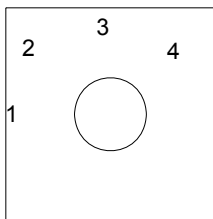

C441

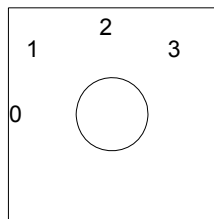

C442

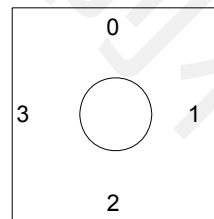

C491

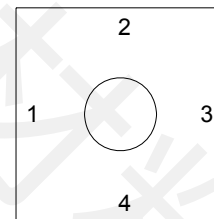

C492

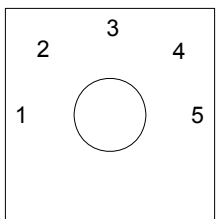

C541

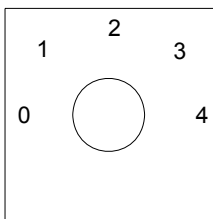

C542

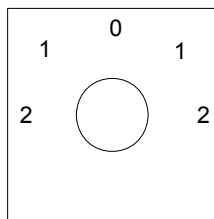

C543

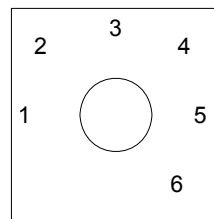

C641

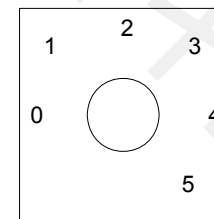

C642

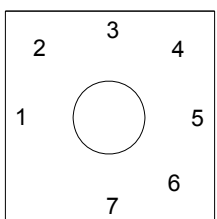

C741

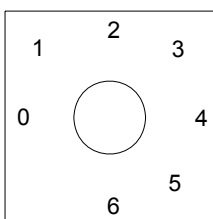

C742

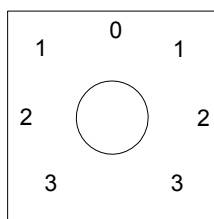

C743

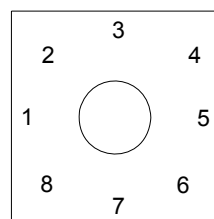

C841

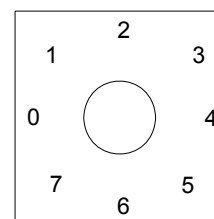

C842

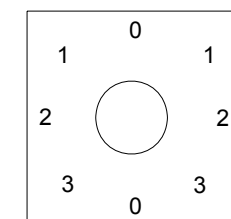

C843

铭板编号(Name Plate No.) : NCS-K7K241

76x76mm

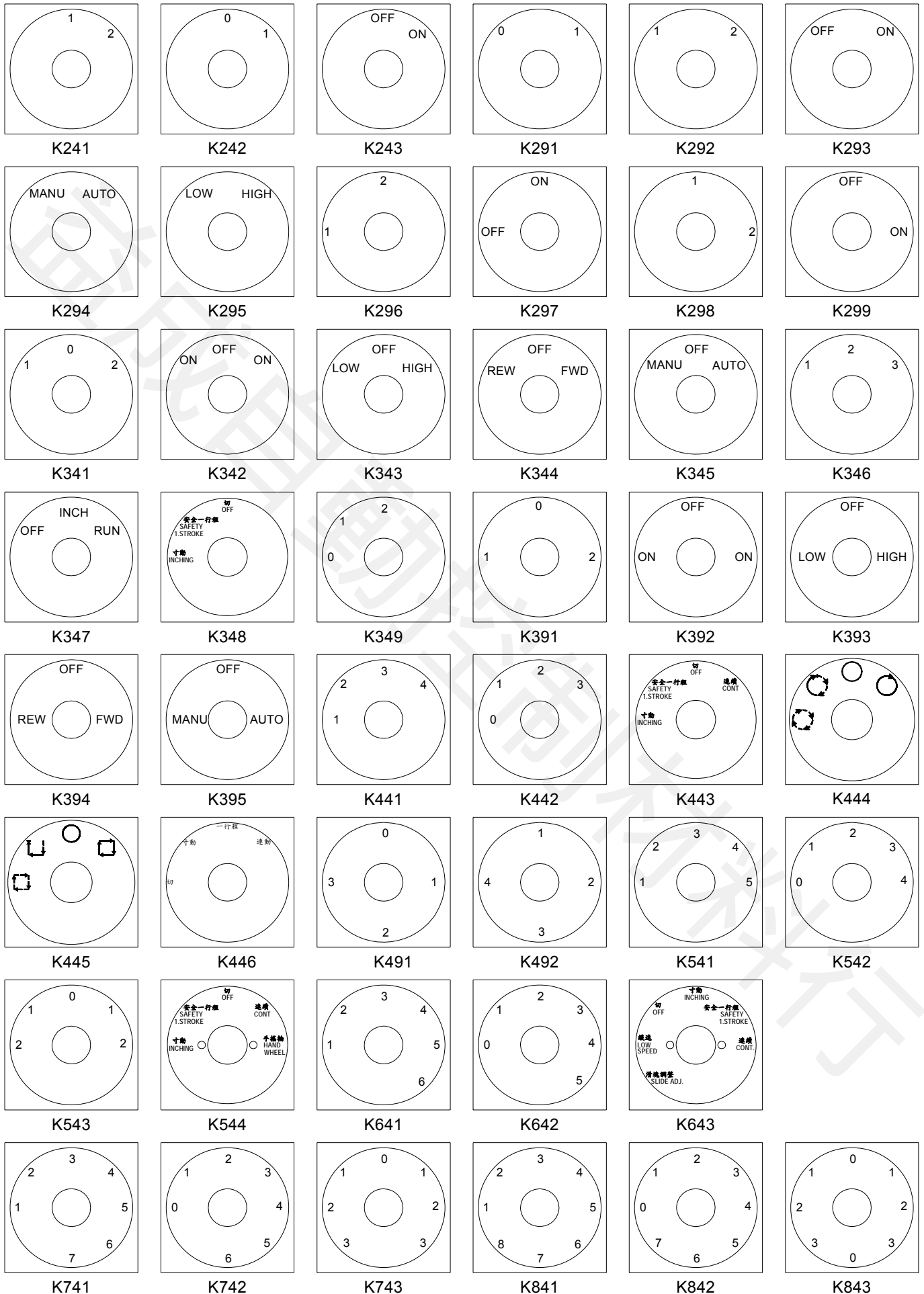

銘板編號(Name Plate No.) : **NCS-S5P261**

65x65mm

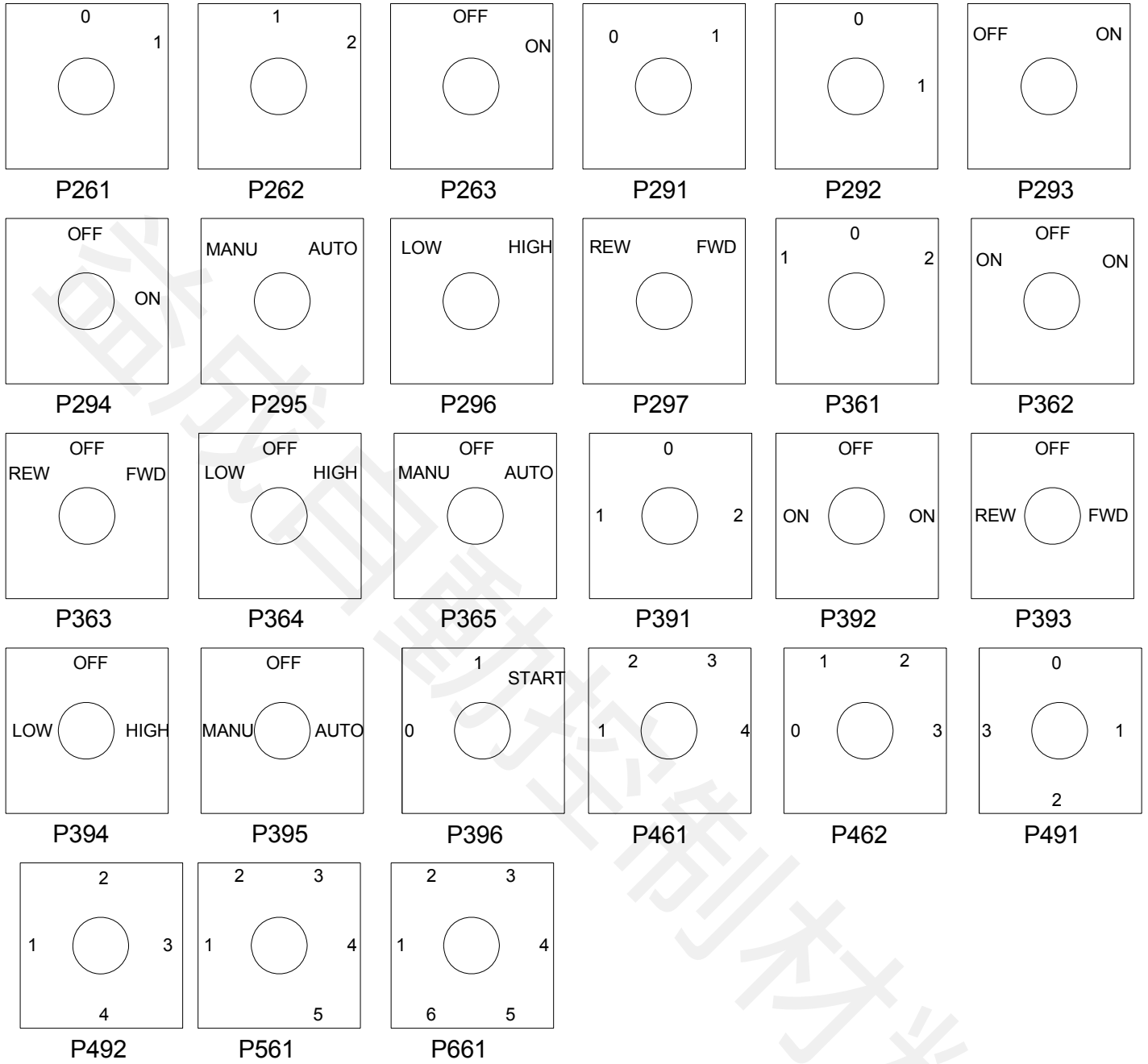

銘板編號(Name Plate No.) : **NCS-P5P298**

65x65mm

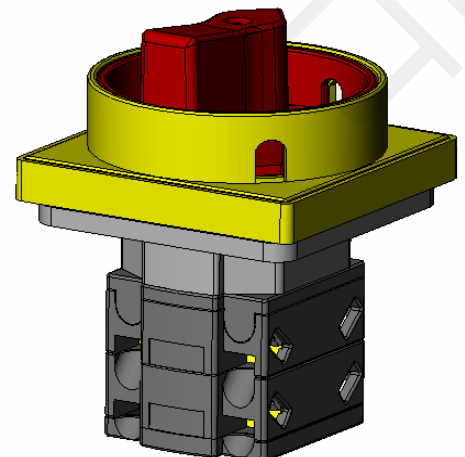
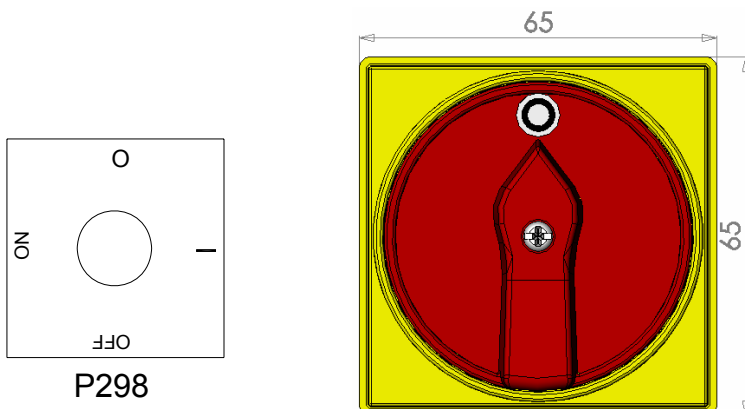

銘板編號(Name Plate No.) : **NCS-S4S261**

**48x48mm**

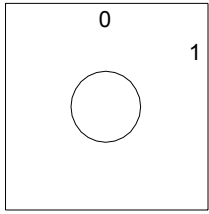

S261

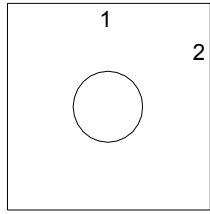

S262

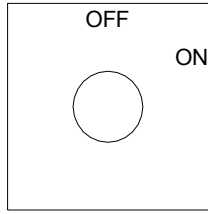

S263

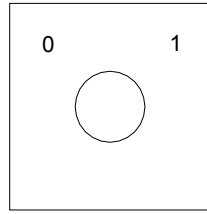

S291

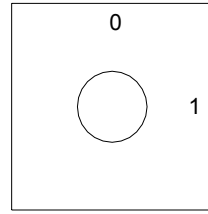

S292

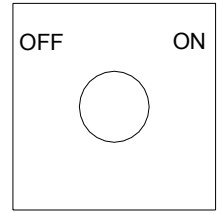

S293

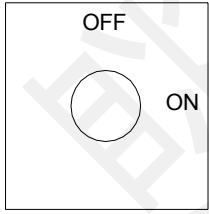

S294

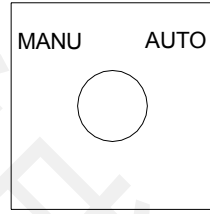

S295

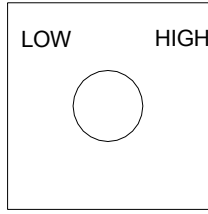

S296

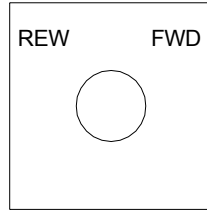

S297

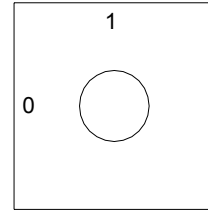

S298

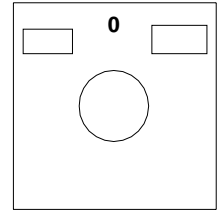

S341

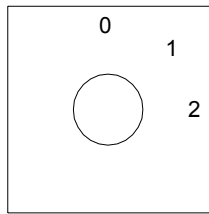

S342

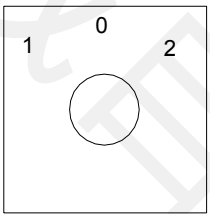

S343

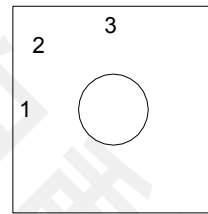

S344

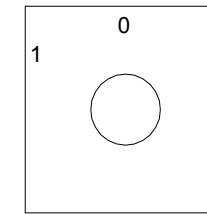

S361

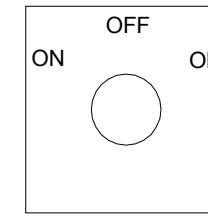

S362

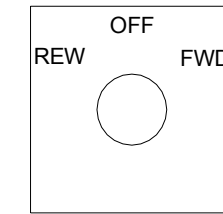

S363

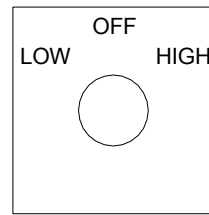

S364

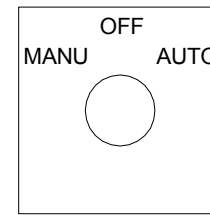

S365

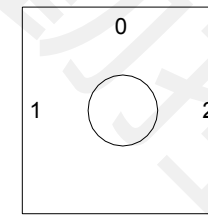

S391

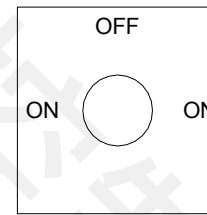

S392

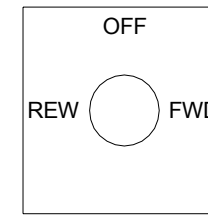

S393

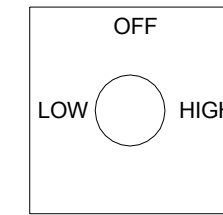

S394

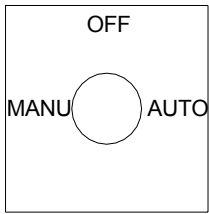

S395

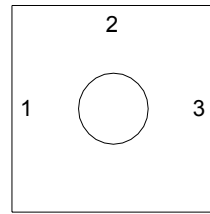

S396

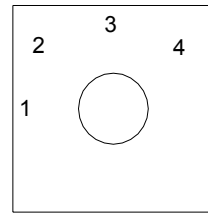

S441

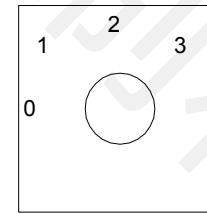

S442

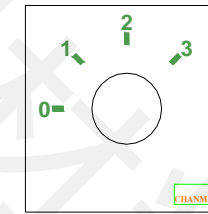

S443(銓麥)

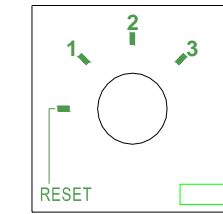

S444(銓麥)

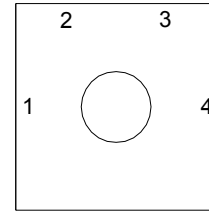

S461

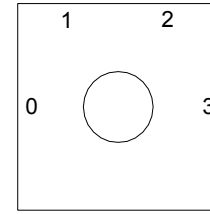

S462

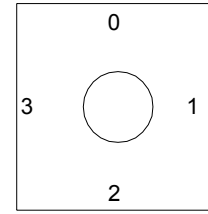

S491

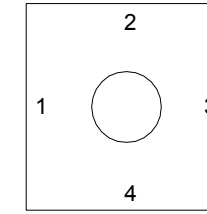

S492

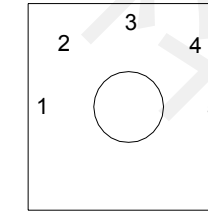

S541

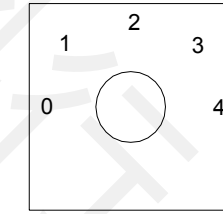

S542

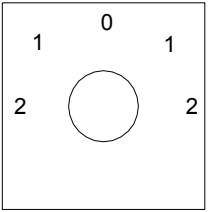

S543

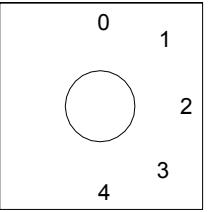

S544

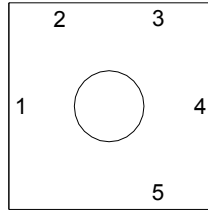

S561

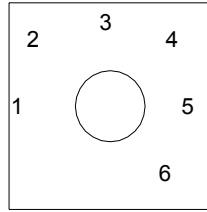

S641

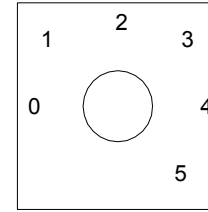

S642

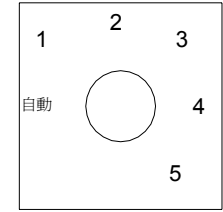

S643



銘板編號(Name Plate No.) : **NCS-S4S261**

**48x48mm**

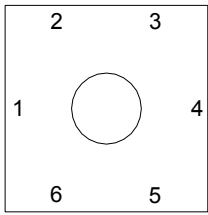

S661

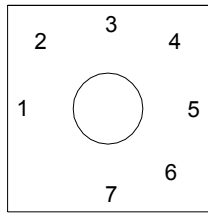

S741

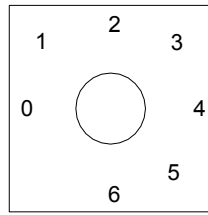

S742

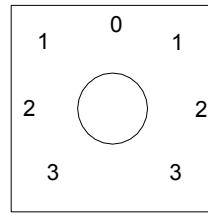

S743

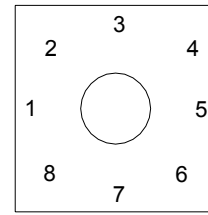

S841

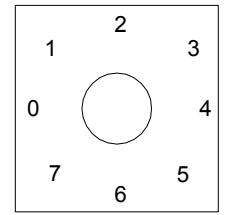

S842

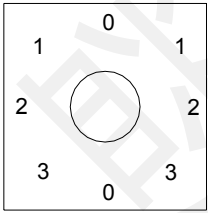

S843

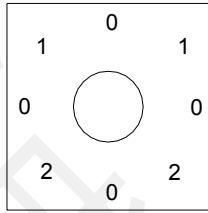

S844

# 多段式切換開關 / CAM SWITCHES

## 一層 (One Tier) :

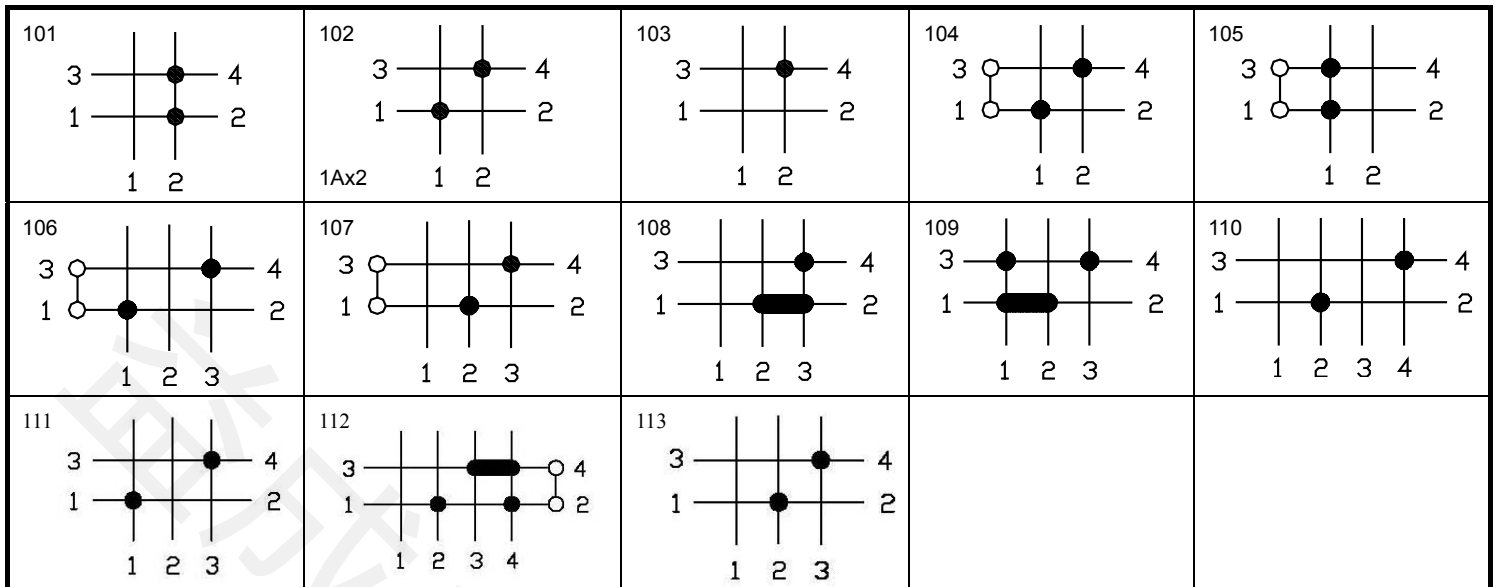

## 二層 (Double Tiers) :

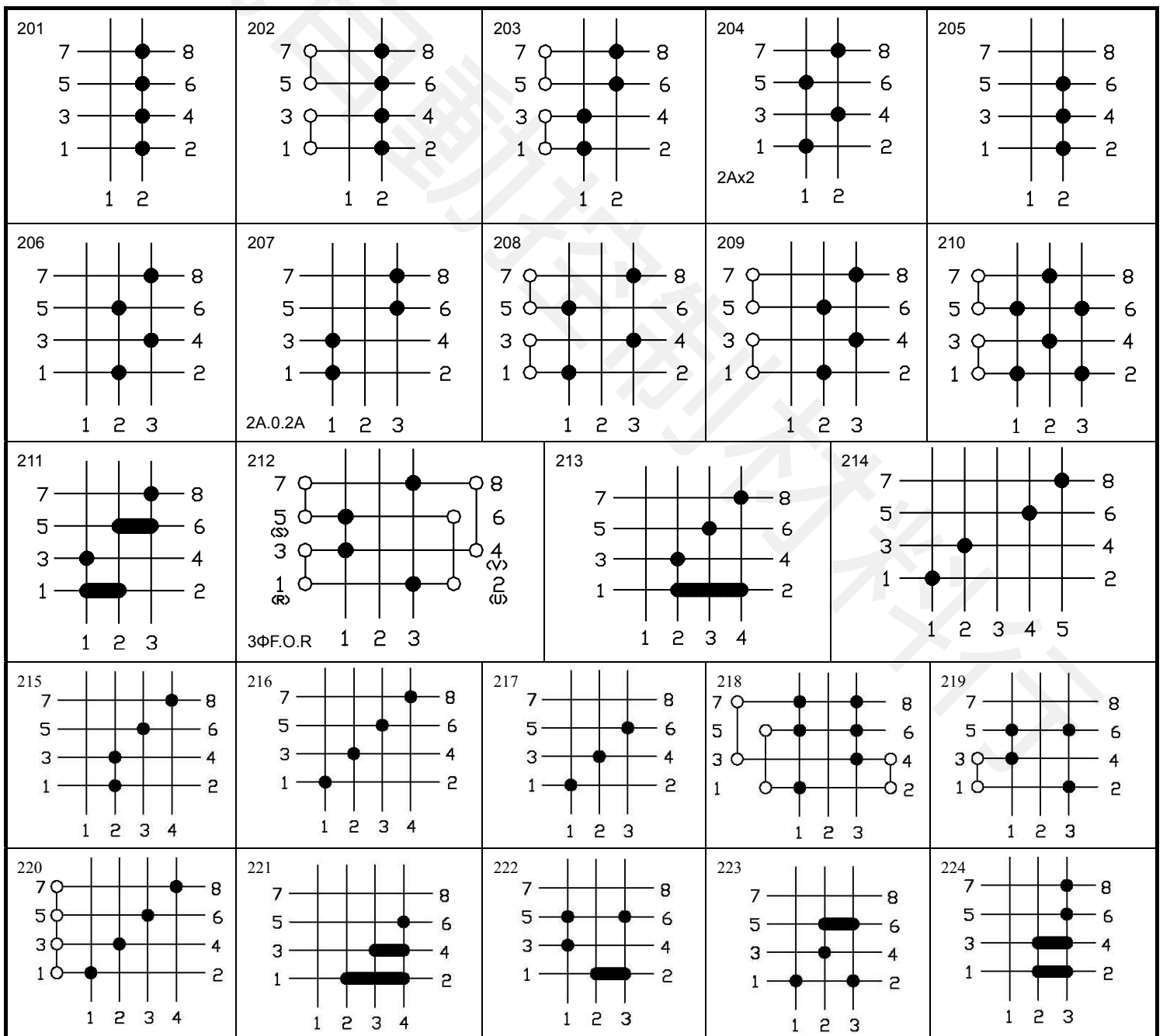

# 多段式切換開關 / CAM SWITCHES

## 二層 (Double Tiers) :

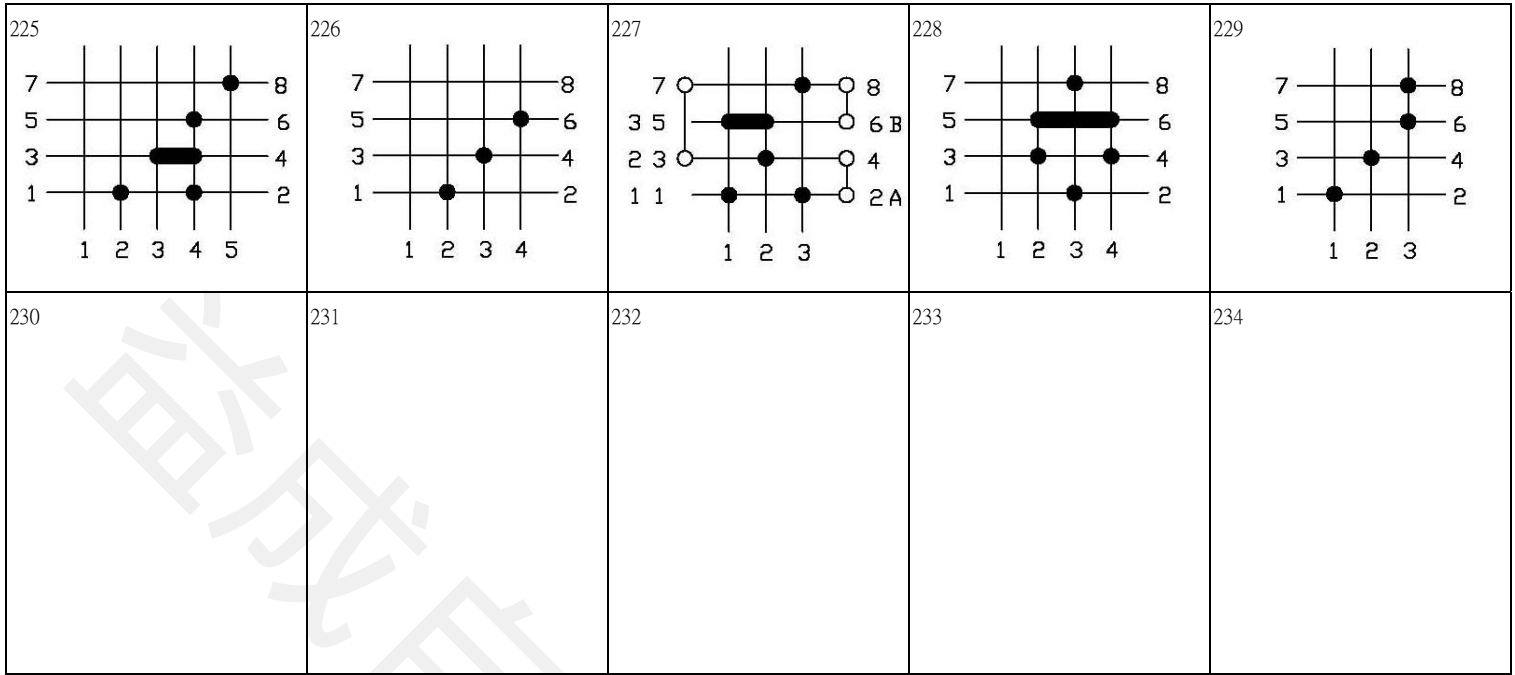

## 三層 (Three Tiers) :

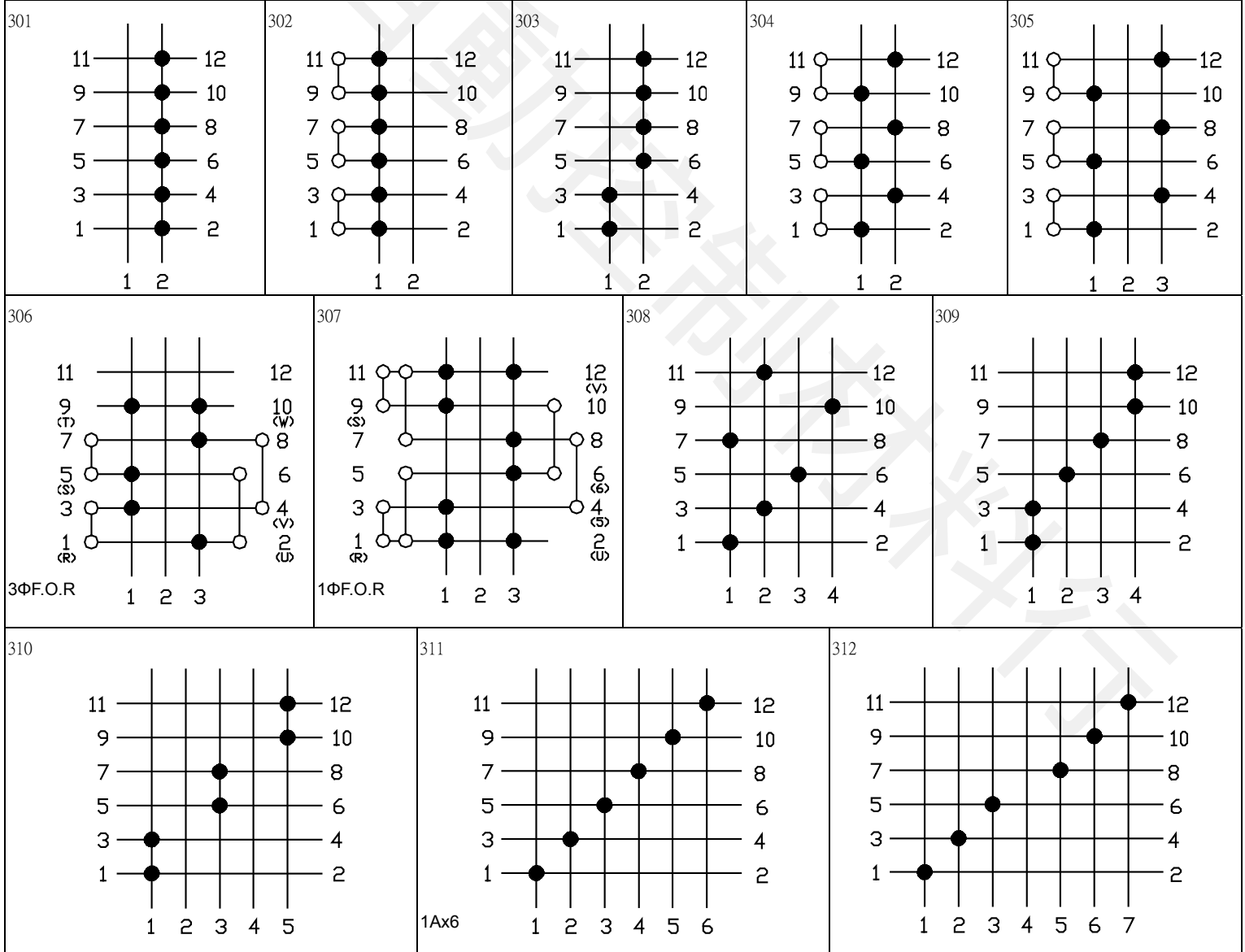

三層 (Three Tiers) :

<p>313</p>	<p>314</p>	<p>315</p>	<p>316</p>
<p>317</p>	<p>318</p>	<p>319</p>	<p>320</p>
<p>321</p>	<p>322</p>	<p>323</p>	<p>324</p>
<p>325</p>			

## 四層 (Four Tiers) :

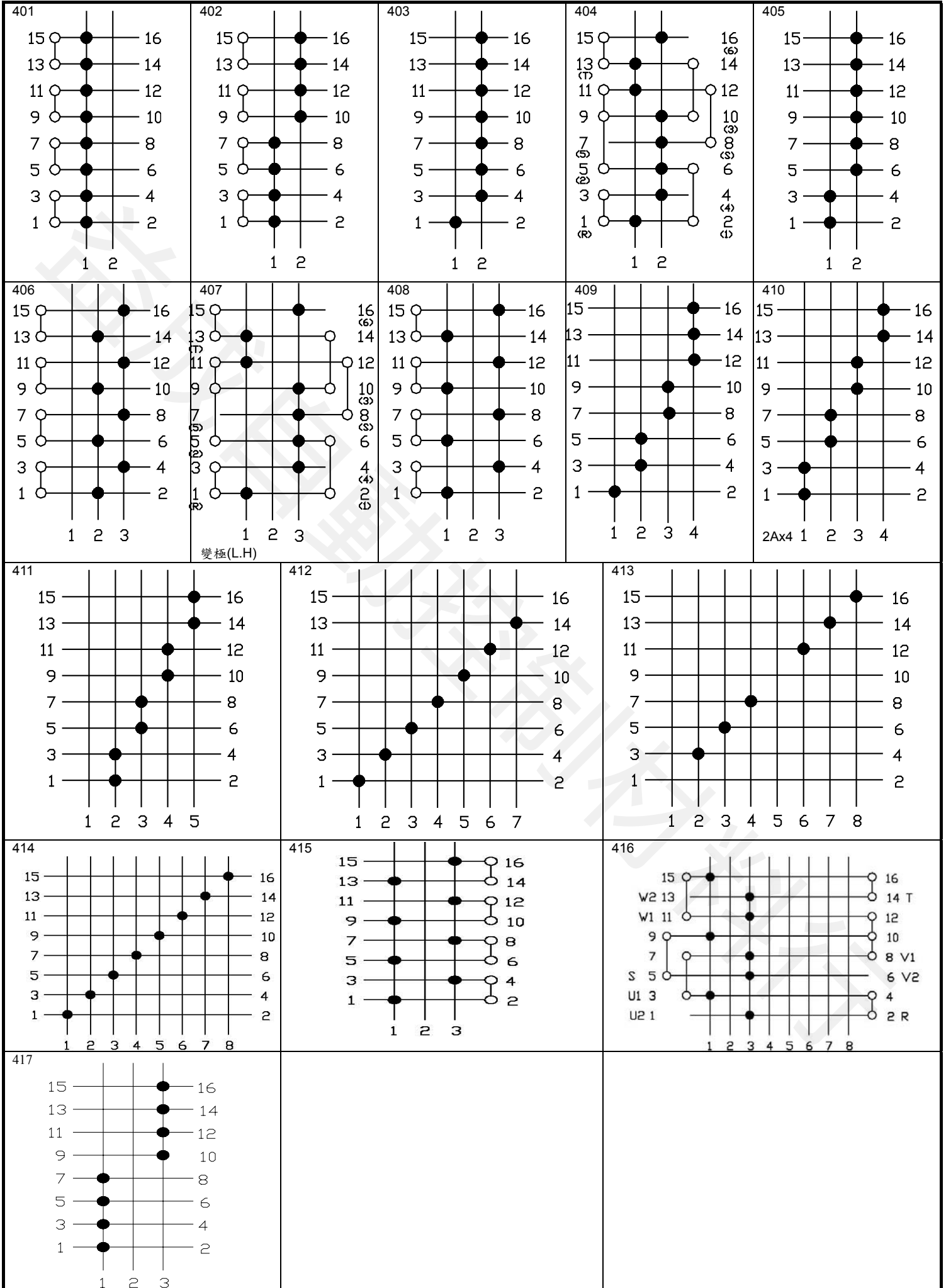

四層 (Four Tiers) :

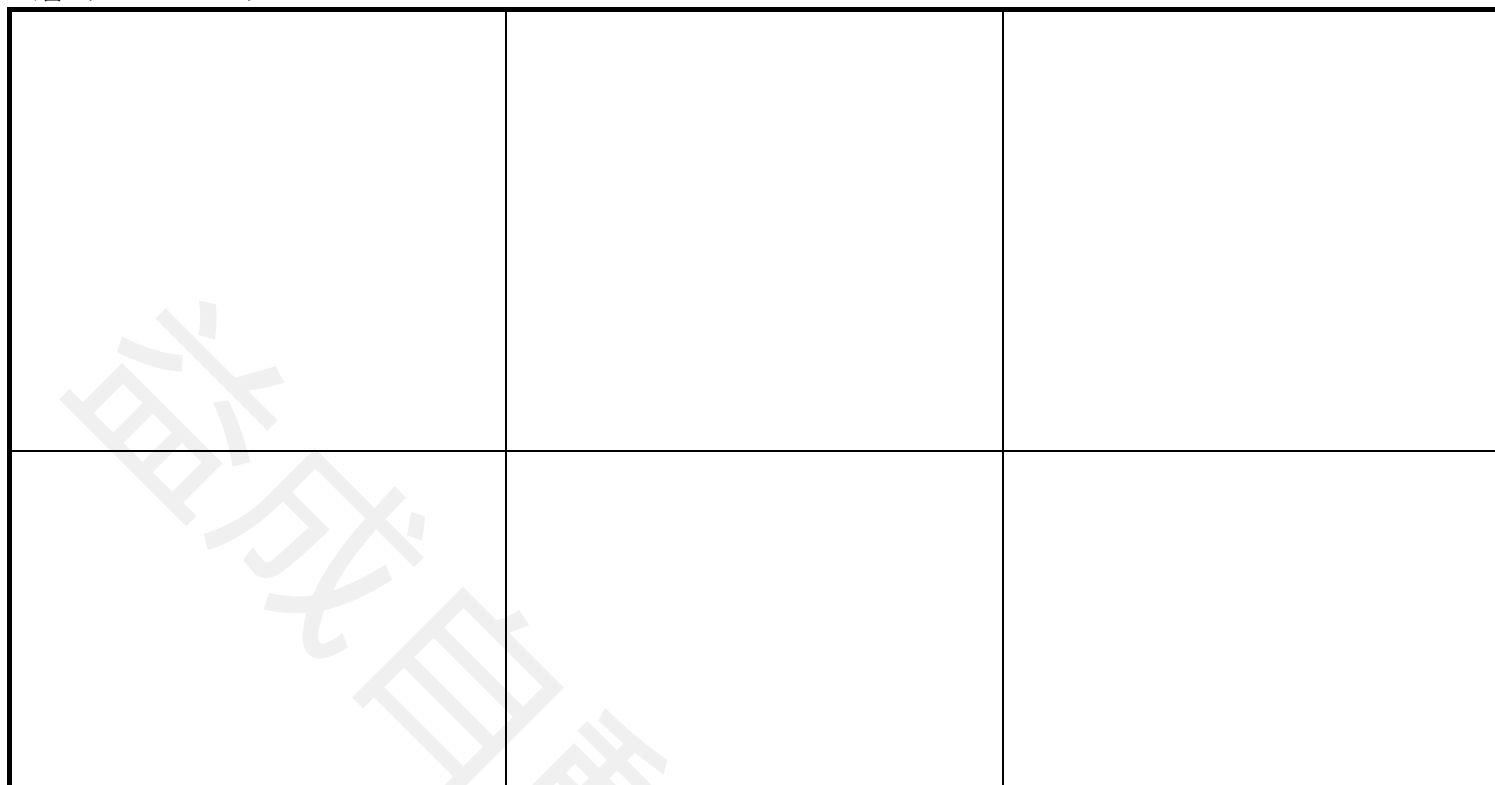

五層 (Five Tiers) :

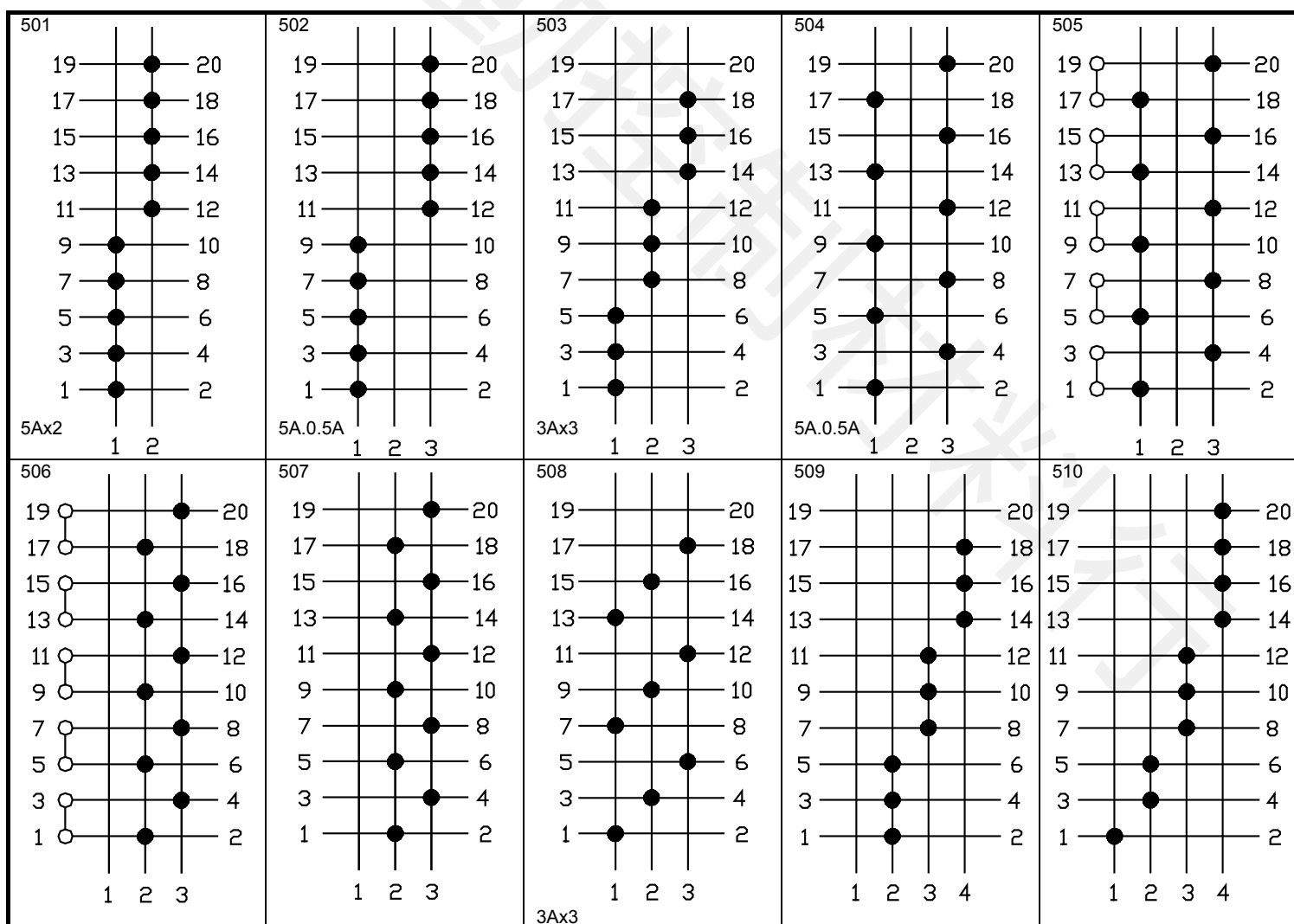

五層 (Five Tiers) :

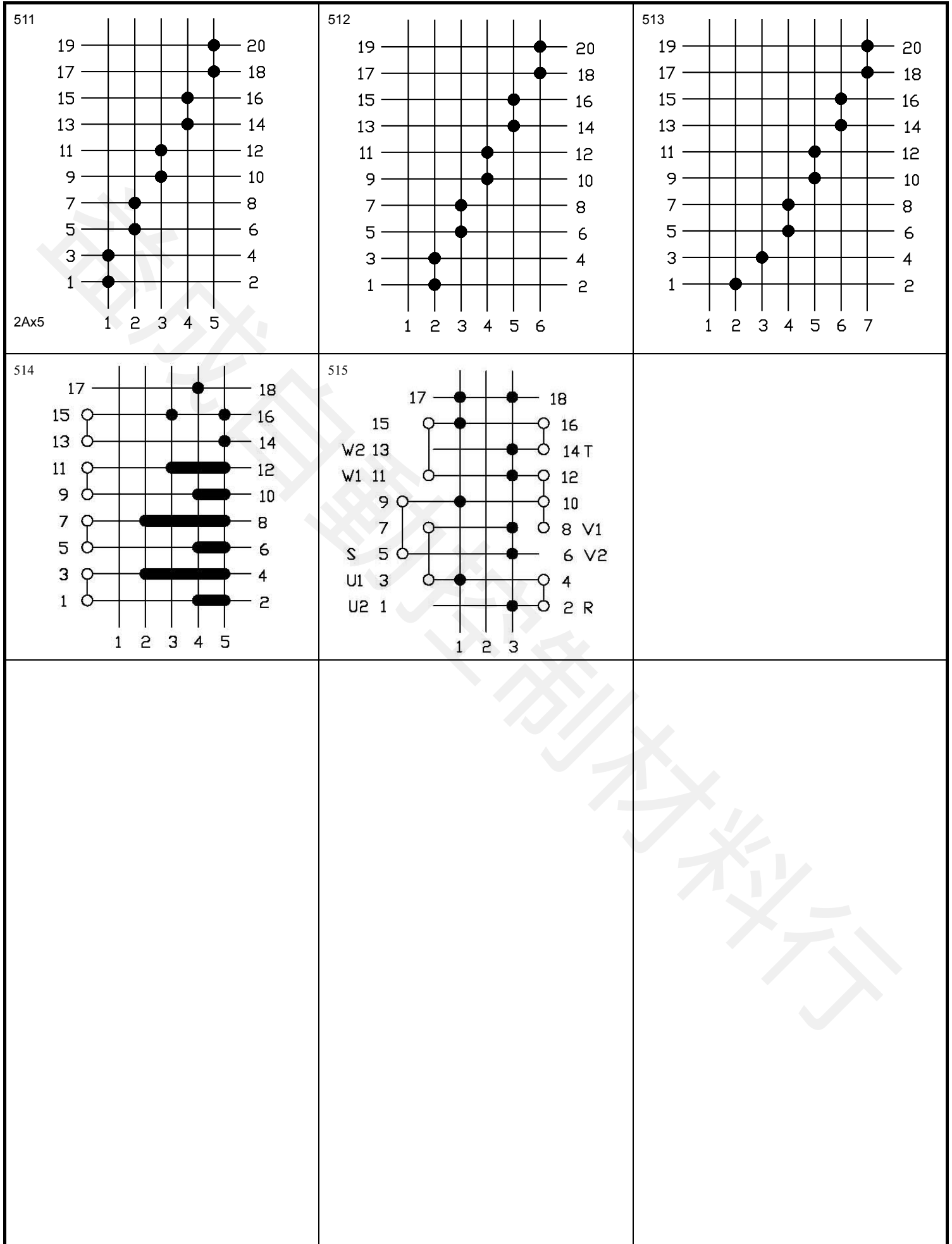

# 多段式切換開關 / CAM SWITCHES

六層(Six Tiers):

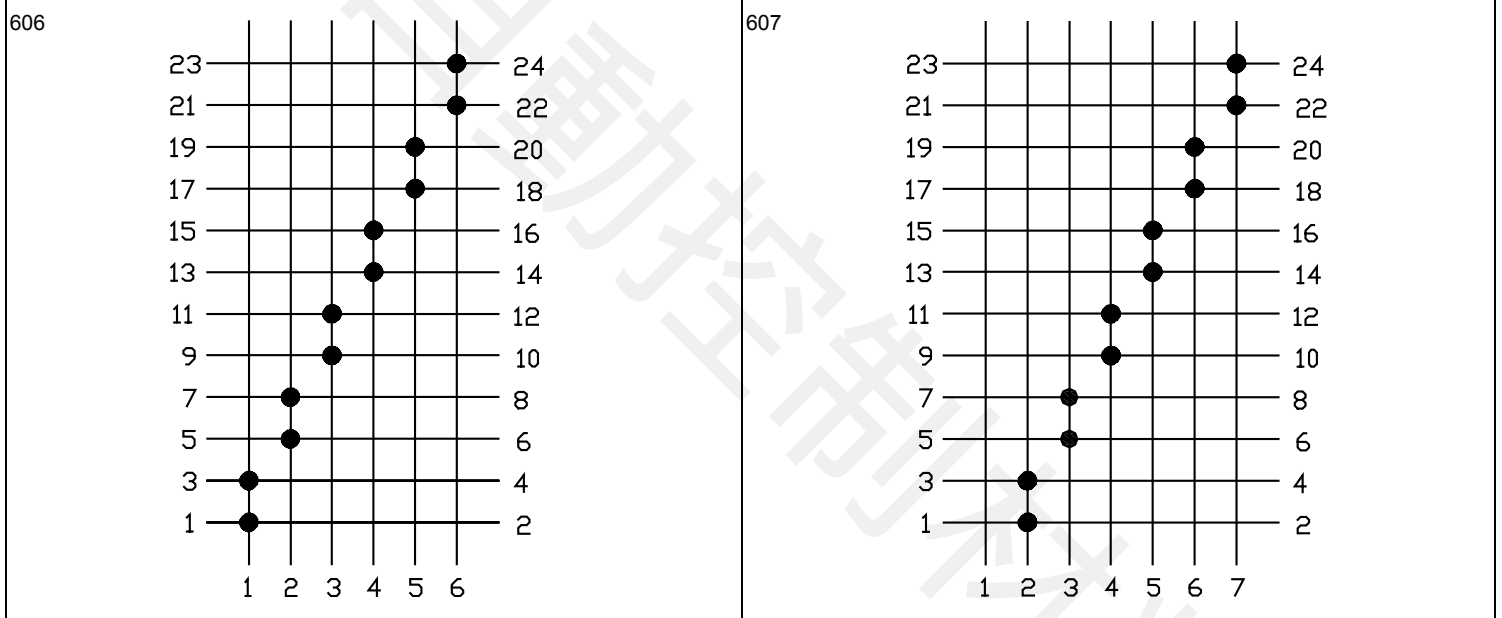
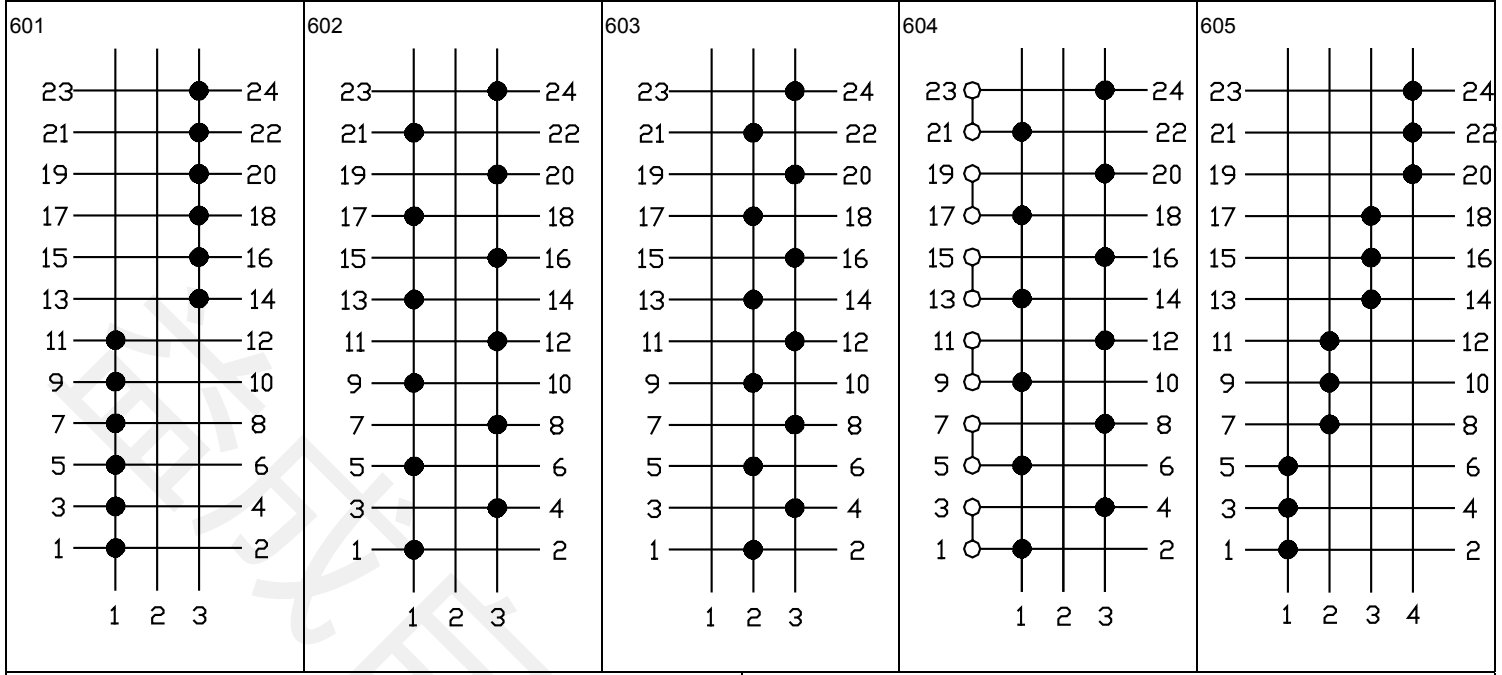



NCS-S6

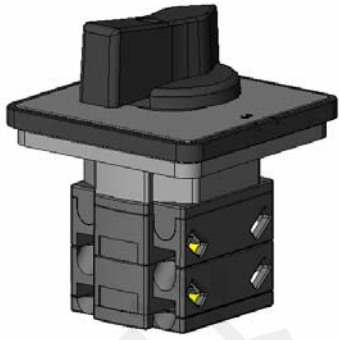

NCS-L6

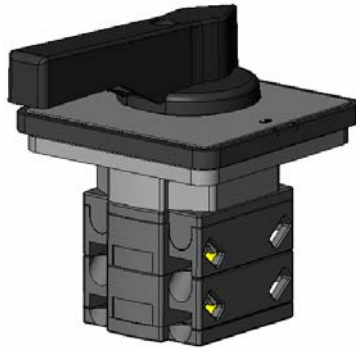

NCS-O6

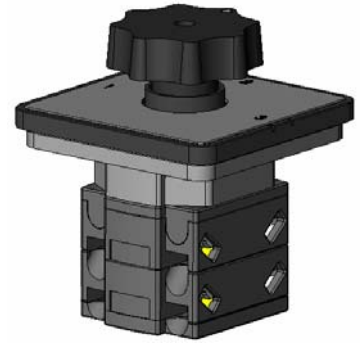

NCS-S8

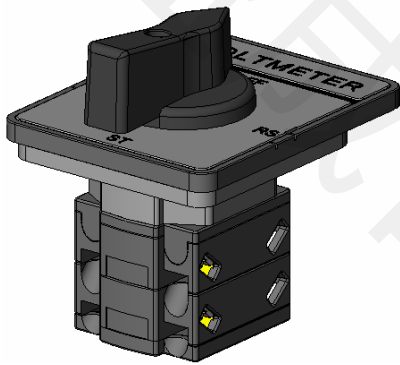

NCS-L8

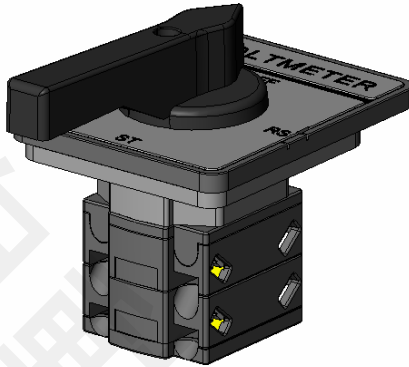

NCS-O8

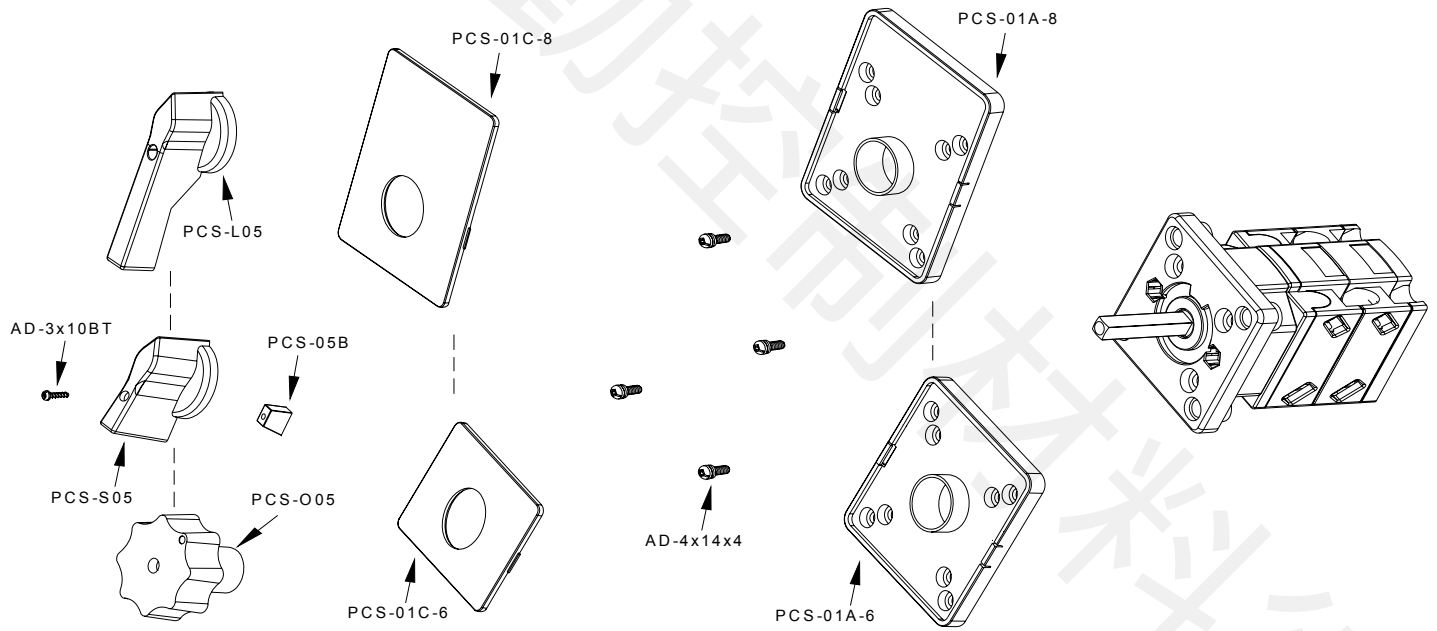
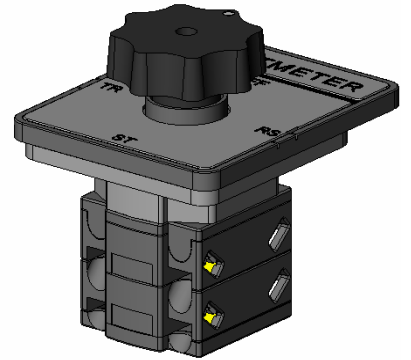

NCS-K7

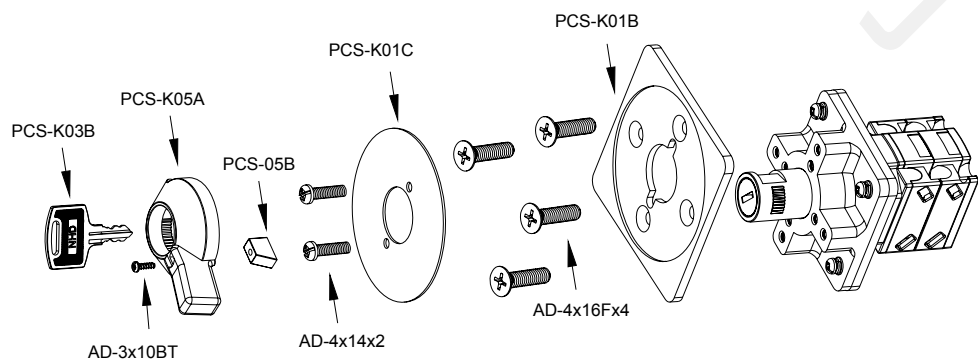
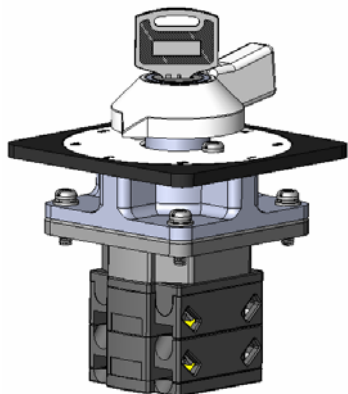

NCS-P5

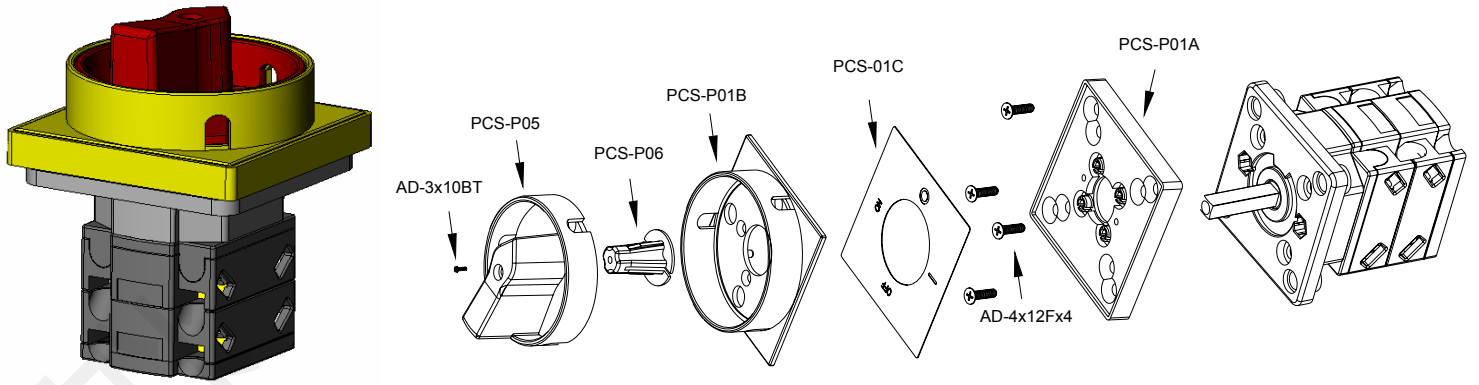

NCS-S5

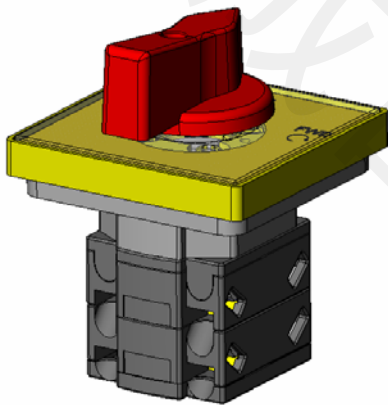

NCS-L5

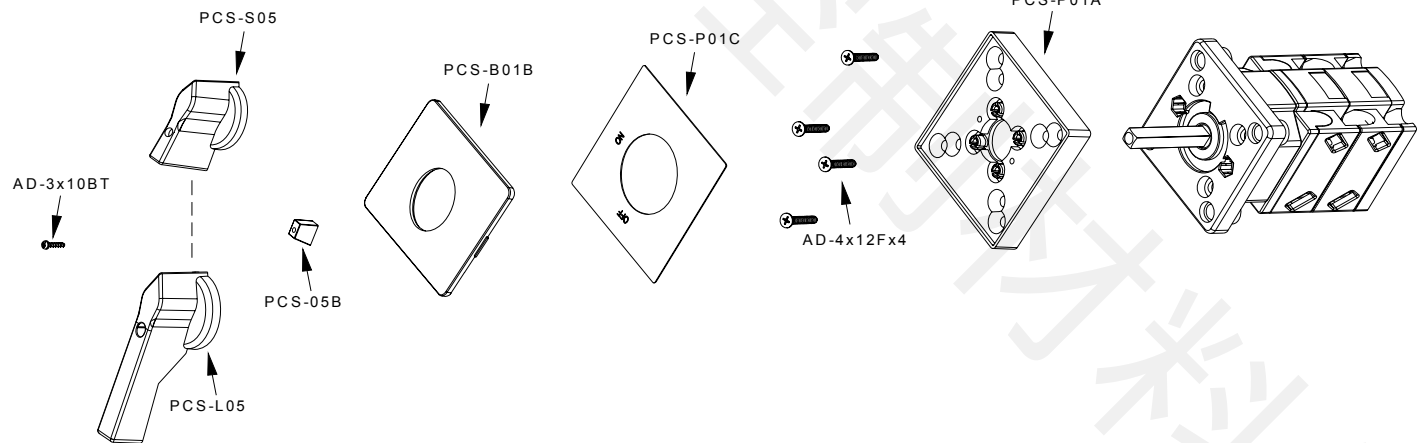
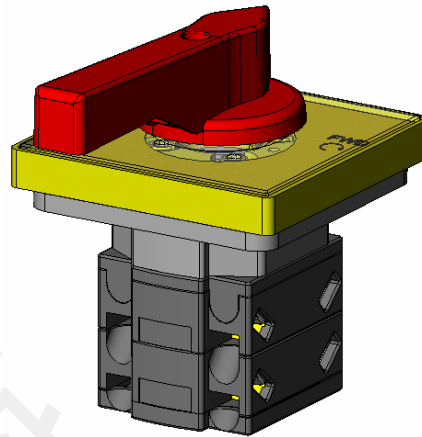

NCS-S4

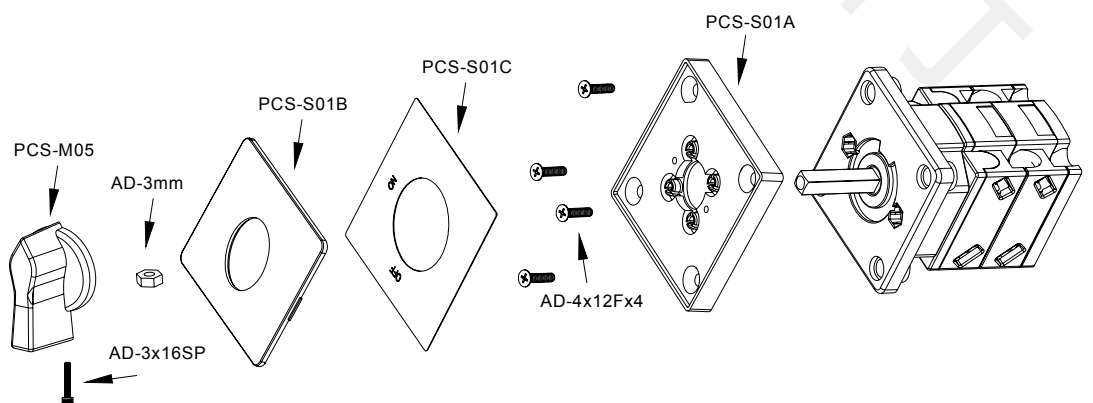
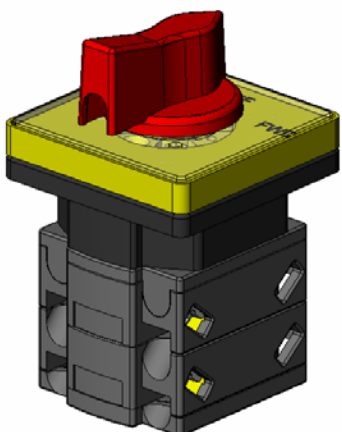

# 多段式切換開關 / CAM SWITCHES

特殊接點訂購格式 (Special Form) :

▶ 客戶如有特殊接點需求，請影印下方空白接點圖後再畫上所需的接點方式。  
(If you need specially made product, please copy the form below and draw the contact you want.)

**NCS-**

1      2      3      4      5

▶ 請參閱第一頁寫下要求。(Please see P1 for reference.)

復歸型式(Spring Return) :

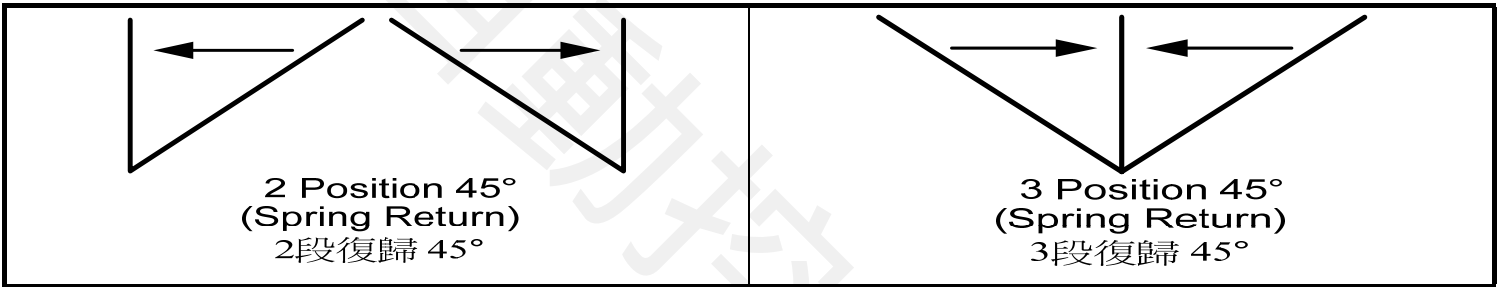

一層(One Tier)

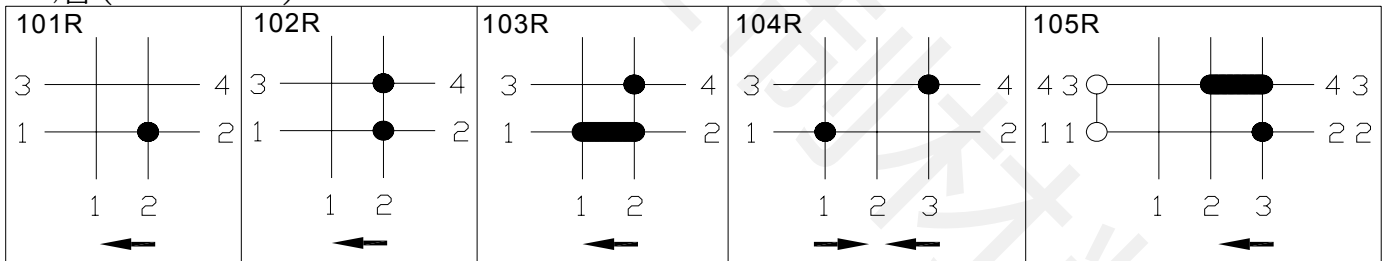

二層(Double Tiers)

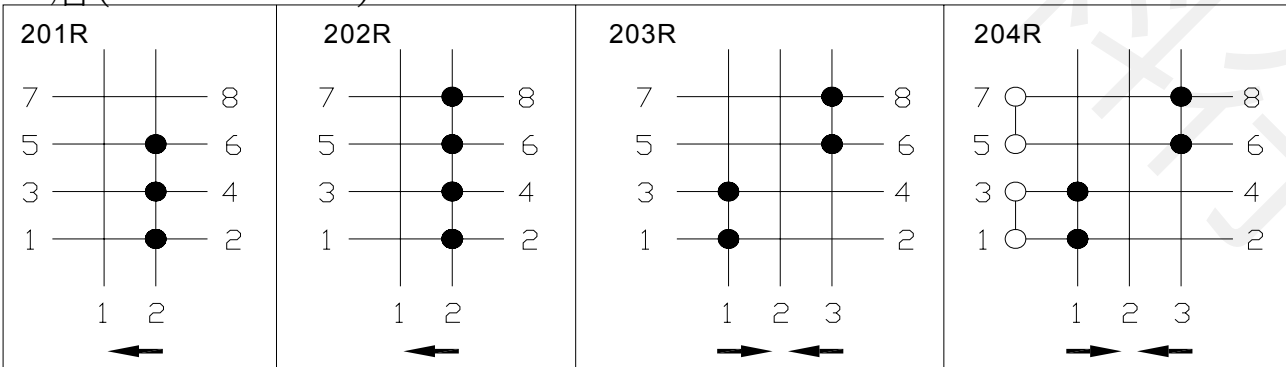

附件 (Accessories) :

