

OMRON

NEW

Valve Sensors

E2MP

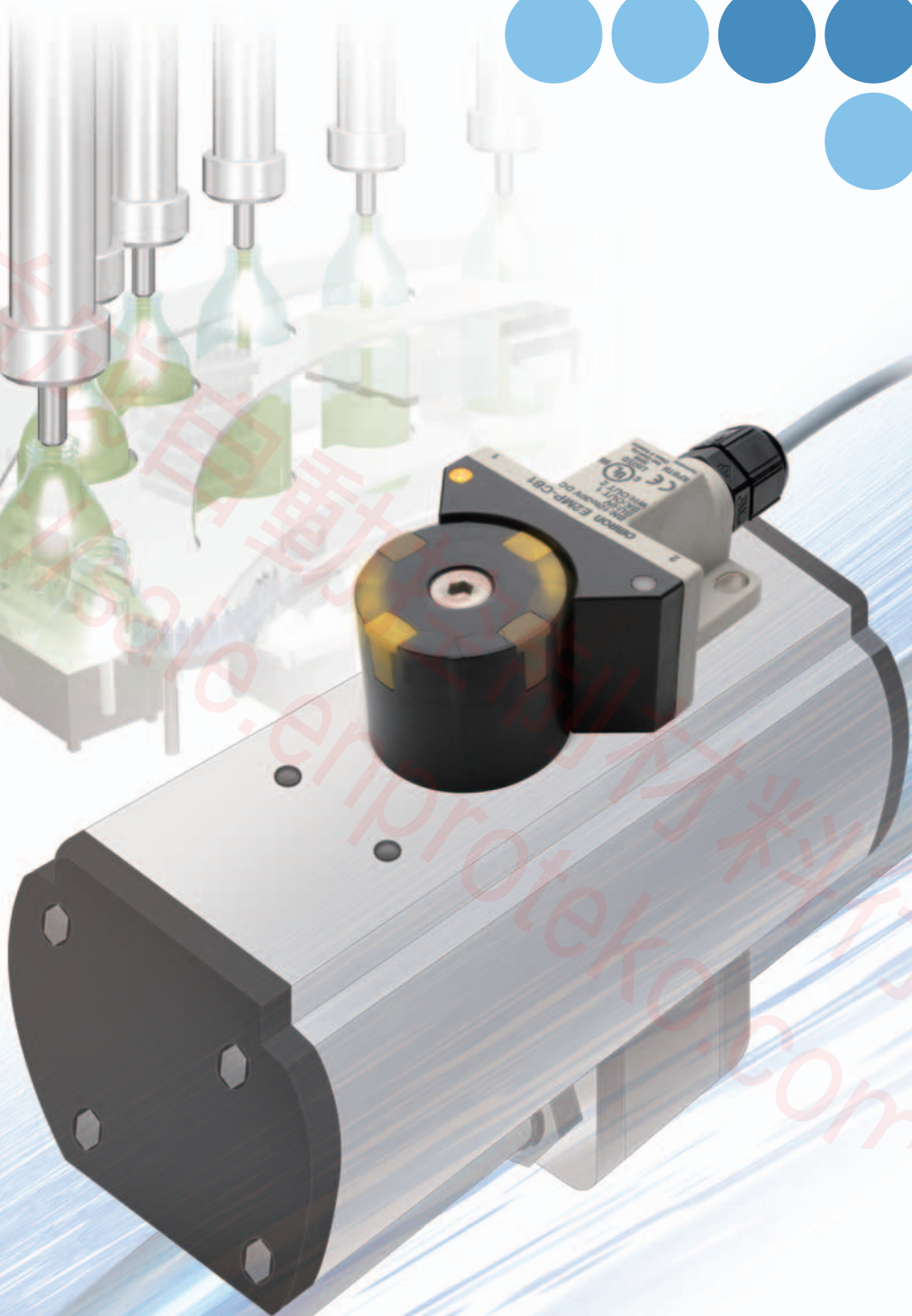
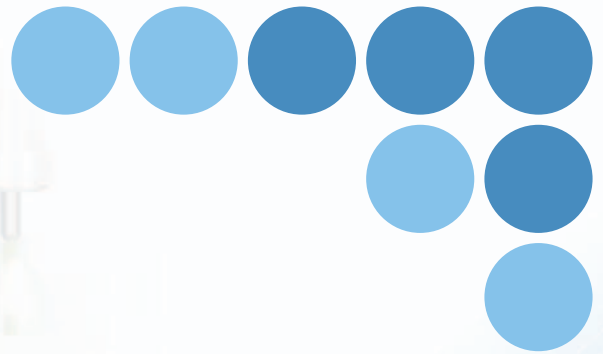

Easily Detect Whether a Fluid Control Valve is Open or Closed with One Sensor.

realizing



Note: UL certification has been obtained only for the DC three-wire models.

Valve Sensors E2MP

Detect Whether a Valve Is Open or Closed
by Mounting Directly on an Actuator

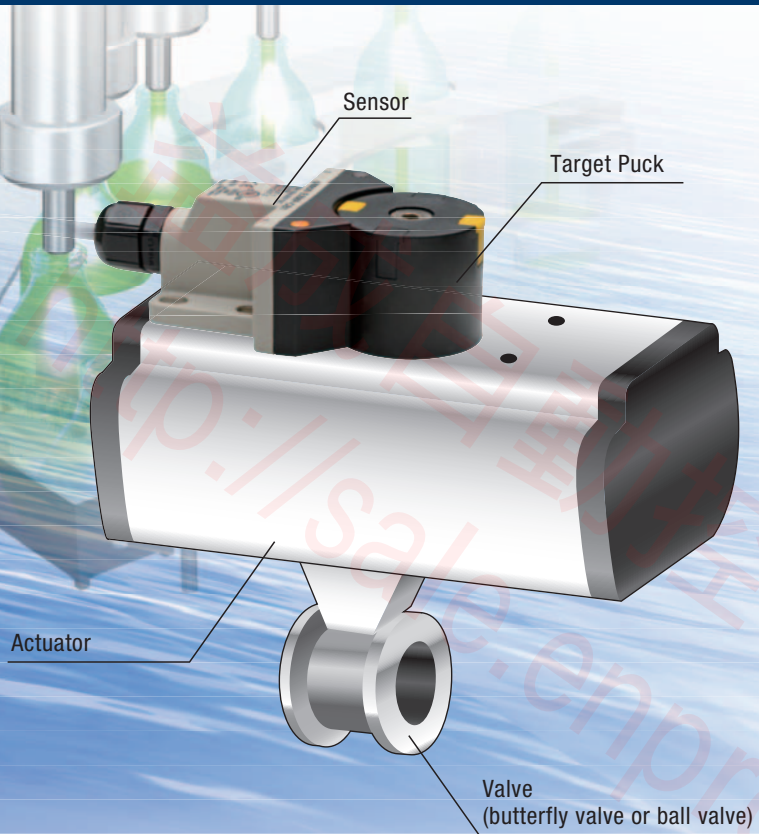

Valve Sensor Detection Mechanism

Two coils built into the Valve Sensor detect the position of metal built into the Target Puck, and separate outputs are provided for when the valve is open or closed.

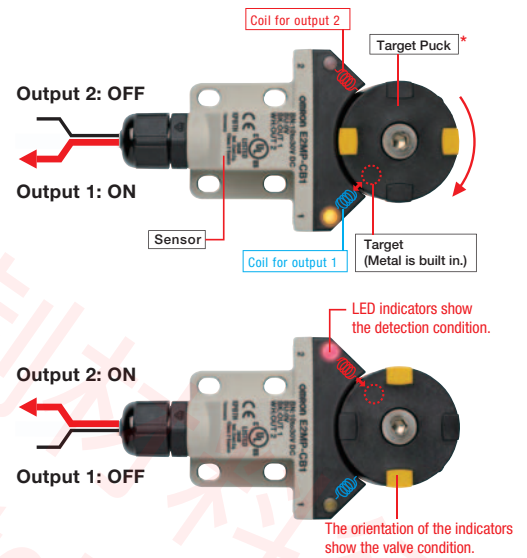

Concerned about installation work?

- The E2MP enables easy mounting with greatly reduced installation work.

Detection section design required every time the valve changes?

- Just select the Valve Sensor and the Target Puck.

Hard to see whether the valve is open or closed at the worksite?

- Easy to see if the valve is open or closed.

The design of the mounting sections of the Valve Sensors and Accessories conform to the VDI/VDE3845 (NAMUR) standard. The Valve Sensors are specially designed to detect valve condition, so the previously required assembly and adjustment work is no longer necessary, greatly reducing installation work.

Note: The VDI/VDE3845 (NAMUR) is an interface standard for valve actuators.

In addition to Target Pucks with specifications for fully closed and Fully open (0°: closed, 90°: open), the product lineup also includes E2MP-CA □ Target Pucks applicable for intermediate opening (0°: closed, 0° to 90°: open), and E2MP-SA □ Target Pucks for mounting to a wide variety of actuator sizes up to a maximum diameter of 85 mm.

Indicators on the Valve Sensor (LED) and the Target Puck* instantly show the valve condition for each confirmation onsite. Two colors of LED indicators, yellow and red, are provided on the Sensors.

Rating / Performance

E2MP-C Series

(for shafts with a 30-mm diameter)

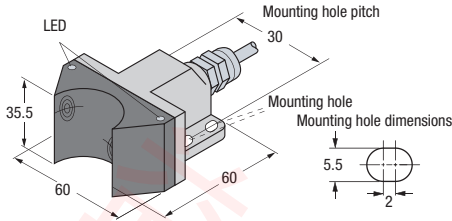

E2MP-S Series

(for shafts with 35 to 85 mm diameter)

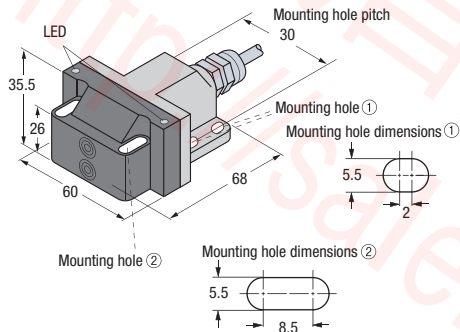

Note: For information on the shaft diameter, refer to the mounting dimensions on the next page.

Item	E2MP-C Series	E2MP-CB1(-M1)	E2MP-CC1(-M1)	E2MP-CT1
	E2MP-S Series	E2MP-SB1(-M1)	E2MP-SC1(-M1)	E2MP-ST1
Output method	DC 3-wire PNP		DC 3-wire NPN	AC/DC 2-wire
Set distance	1 mm max.			
Sensing object	E2MP-C Series: E2MP-CA □		E2MP-S Series: E2MP-SA □	
Power supply voltage	10 to 30 VDC (including ripple (p-p): 10%)		20 to 250 VAC (50/60 Hz), 10 to 300 VDC (including ripple (p-p): 10%)	
Current consumption	15 mA max.		—	
Leakage current	—		1.7mA max.	
Control output	Switching capacity	Open-collector output 200mA max.		AC: 3 to 400 mA, DC: 3 to 300 mA
	Residual voltage	2 V max. with a 2-m cable and up to a 200 mA load current		6 V max. (AC load current: 400 mA, DC load current: 300 mA, Cable length: 2 m)
Indicators	Operation indicator 1: Yellow Operation indicator 2: Red			
Operation mode	NO (normally open) Refer to the timing charts with the I/O Circuit Diagrams for details.			
Protection circuits	Load short-circuit protection, Power supply reverse polarity protection, Output reverse polarity protection		Load short-circuit protection	
Ambient temperature	Operating: -25 to 70°C (with no icing or condensation) Storage: -25 to 70°C (with no icing or condensation)			
Ambient humidity	Operating: 35% to 95% (with no condensation) Storage: 35% to 95% (with no condensation)			
Insulation resistance	50 MΩmin. (at 500 VDC) between current-carrying parts and case			
Dielectric strength	500 VAC, 50/60 Hz for 1 min. between current-carrying parts and case		1,500 VAC, 50/60 Hz for 1 min. between current-carrying parts and case	
Vibration resistance (destruction)	10 to 55 Hz, 1-mm double amplitude for 2 hours each in X, Y, and Z directions			
Shock resistance (destruction)	300 m/s ² 10 times each in X, Y, and Z directions			
Degree of protection	IEC 60529 IP67			
Connection method	Not indicated in model number: Pre-wired Models (Standard cable length: 2 m)		Pre-wired Models (Standard cable length: 2 m)	
	Model number with -M1: M12 Connector Models			
Weight (packed state)	C Series	Pre-wired Models: Approx. 170 g Connector Models: Approx. 90 g		
	S Series	Pre-wired Models: Approx. 190 g Connector Models: Approx. 110 g		
Materials	Case: PP, Display window: PA, Mounting screws and washers: Stainless steel, Cord: PVC (Pre-wired Models), Connectors: Brass nickel plated (Models with Connectors)			
Accessories	Instruction Manual, screws (C Series: M15×12 two screws, S Series: M5×30 two screws, M5×30 two screws, two washers)			

I/O Circuit Diagrams

DC 3-wire (PNP Output)

E2MP-□B1/E2MP-□B1-M1

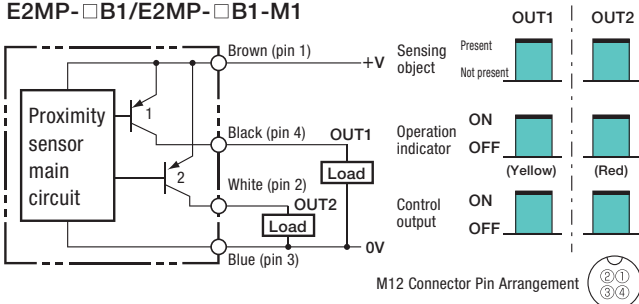

Applicable OMRON connector cable: X2SF Series

DC 3-wire (NPN Output)

E2MP-□C1 / E2MP-□C1-M1

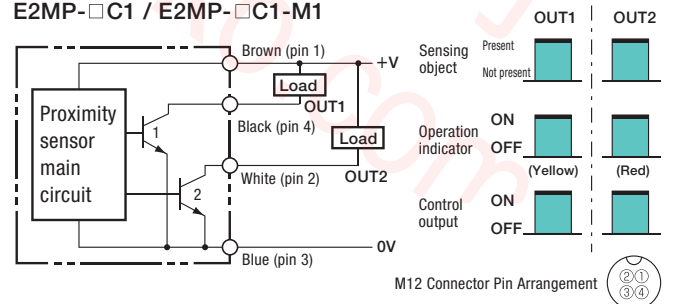

Applicable OMRON connector cable: X2SF Series

AC/DC 2-wire

E2MP-□T1

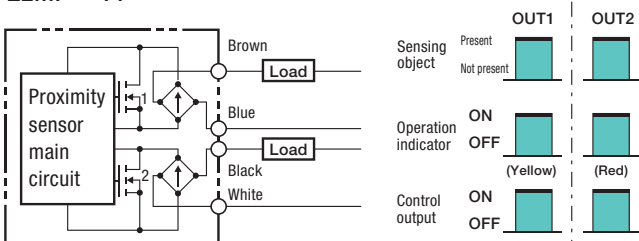

*The load can be connected to either the +V or 0V side. There is also no reason to consider the polarity of the Valve Sensor.

Safety Precautions

WARNING

This product is not designed or rated for ensuring safety of persons either directly or indirectly. Do not use it for such purposes.

Never use an AC power supply for a Valve Sensor specified for a DC power supply. Otherwise, the Valve Sensor may rupture.



Target Puck

Model	Target Puck for E2MP-C Series			Target Puck for E2MP-S Series		
	E2MP-CA1	E2MP-CA2	E2MP-CA3	E2MP-SA1	E2MP-SA2	E2MP-SA3
Specifications	Fully open or fully closed (0°: closed, 90°: open)	Fully open or fully closed, converted to NC (0°: closed, 90°: open)	Fully closed or intermediate opening (0°: closed, 0° to 90°: open)	Fully open or fully closed (0°: closed, 90°: open)		
Applicable shaft size	Height	20 mm, 30 mm		20 mm	30 mm	30 mm
	Maximum diameter	30 mm		35 mm	50 mm	85 mm
Materials	Case: PP, Target: Stainless steel	Case: Aluminum	Case: PP, Target: Stainless steel	Case: PA, Target: Stainless steel		
Weight (packed state)	Approx. 30 g	Approx. 65 g	Approx. 30 g	Approx. 45 g	Approx. 60 g	Approx. 100 g

Mounting Dimensions

(Unit:mm)

E2MP-C Series

E2MP-CA1, CA3

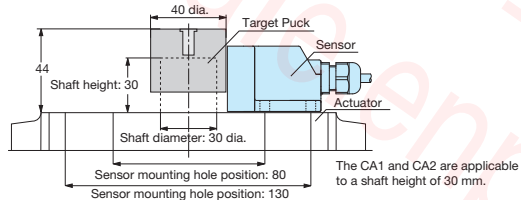
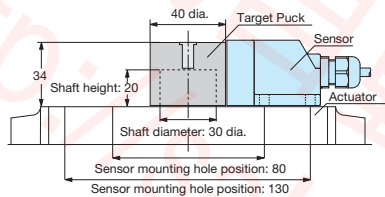

E2MP-CA2

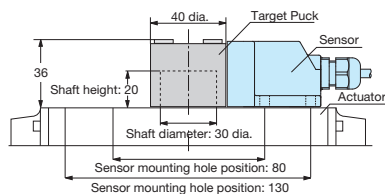

E2MP-S Series

E2MP-SA1

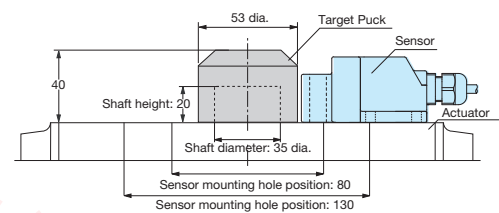

E2MP-SA2

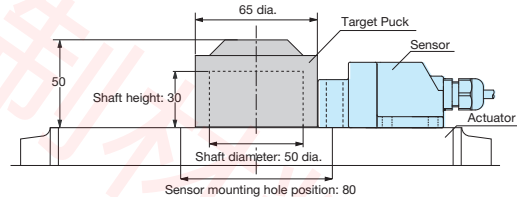

E2MP-SA3

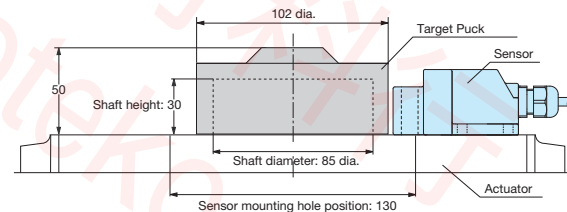

Sensor mounting: M5 screws, Target Puck: M6 screws

Ordering Information

Series	Output	Model	
		Pre-wired Models	Connector Models
E2MP-C Series	DC 3-wire PNP	E2MP-CB1 2M	E2MP-CB1-M1
	DC 3-wire NPN	E2MP-CC1 2M	E2MP-CC1-M1
	AC/DC 2-wire	E2MP-CT1 2M	—
E2MP-S Series	DC 3-wire PNP	E2MP-SB1 2M	E2MP-SB1-M1
	DC 3-wire NPN	E2MP-SC1 2M	E2MP-SC1-M1
	AC/DC 2-wire	E2MP-ST1 2M	—

Series	Model
E2MP-C Series	E2MP-CA1
	E2MP-CA2
	E2MP-CA3
E2MP-S Series	E2MP-SA1
	E2MP-SA2
	E2MP-SA3