

**RN**

# Rectangular Inductive Proximity Sensor

## ◆Characteristic/特點：

- The IP67 rating is designed to the effective waterproof.  
/保護結構達到IP67的規格，能有效的防水
- Build-in twin LED, convenient for checking the operation.  
/具有雙LED，檢測操作更方便
- Plug-in connector type is available, easy to connect, anyone can replace the new sensor in a minute.  
/插入式接線，安裝更換很容易
- Oval hole for easy installation and adjustment.  
/具有長形孔，可容易微調安裝



## ◆Specifications / 規格表：

Area Sensor 輸出模式	Output method / 輸出模式	NPN N.O.	<b>RN04-N</b>	<b>RN04-ND1</b>
		NPN N.C.	<b>RN04-N2</b>	-
		PNP N.O.	<b>RN04-P</b>	<b>RN04-PD1</b>
		PNP N.C.	<b>RN04-P2</b>	-
Sensing Surface / 檢測方向		Top surface / 前方		
Standard sensing object / 標準檢測物		Iron 18x18x1mm		
Sensing distance / 檢出距離		5mm		
Secure sensing distance / 建議距離		0to4mm		
Hysteresis / 滯滯		≤ 10% of sensing distance		
Response time / 反應時間		2ms Max		
Operating voltage / 工作電壓		DC 10 ~ 30V		
Current consumption / 消耗電流		≤ 8 mA no-load		
Load current / 負載電流		100 mA Max at DC 30V		
Leakage current / 漏電流		≤ 1.1 mA no-load		
Residual voltage / 殘餘電壓		≤ DC 1.5V		
Insulation resistance / 隔離阻抗		20M Ω min. (DC500V)		
Voltage withstandability / 絕緣耐壓		AC1000V 60Hz for 60 Sec.		
Operating temperature / 工作溫度範圍		-20°C ~ +60°C		
Protection degree / 防水等級		IP64 / IP67 (Option)		
Wiring method / 出線方式		Ø4.2 x 2M / 3wires	M8 connector / M8 接頭	
Weight / 重量		Approx.60g	Approx.12g	

## ◆Dimensions/尺寸圖：

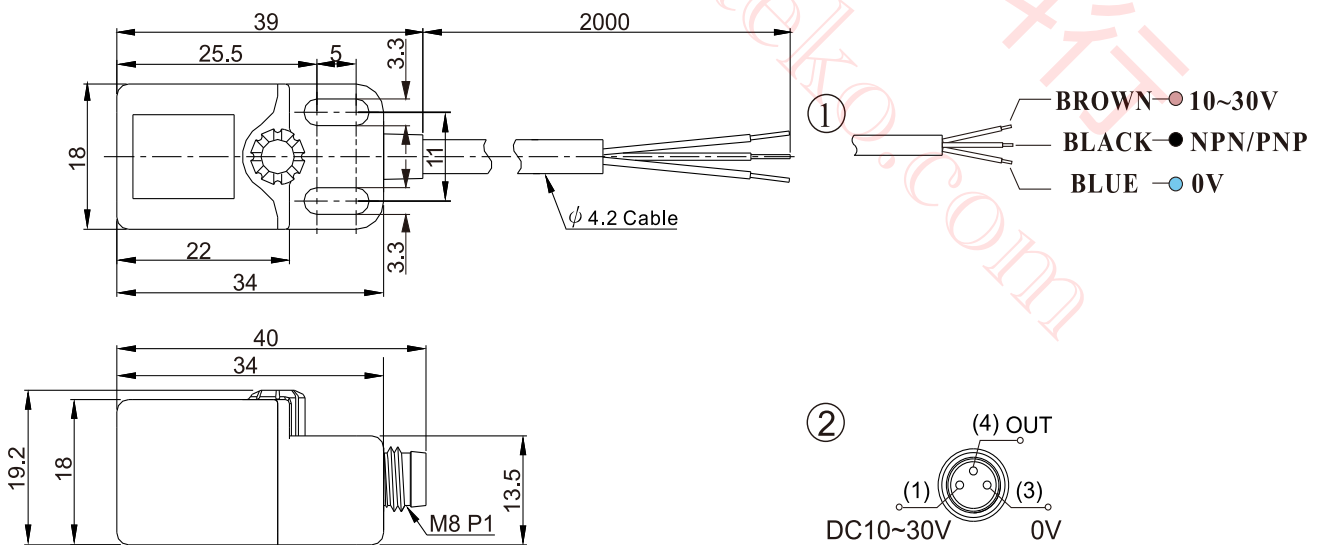

# Rectangular Inductive Proximity Sensor

# RN05

### ◆Characteristic/特點：

- Build-in twin LED, convenient for checking the operaton.  
/具有雙LED，檢測操作更方便
- Plug-in connector type is available, easy to connect, anyone can replace the new sensor in a minute.  
/插入式接線，安裝更換很容易



### ◆Specifications / 規格表：

Output method / 輸出模式	NPN N.O.	RN05-N	RN05-ND1
	NPN N.C.	RN05-N2	-
	PNP N.O.	RN05-P	RN05-PD1
	PNP N.C.	RN05-P2	-
Sensing Surface / 檢測方向		Top surface / 前方	
Standard sensing object / 標準檢測物		Iron 18x18x1mm	
Sensing distance / 檢出距離		5mm	
Secure sensing distance / 建議距離		0to4mm	
Hysteresis / 滯滯		≤10% of sensing distance	
Response time / 反應時間		2ms Max	
Operating voltage / 工作電壓		DC 10 ~ 30V	
Current consumption / 消耗電流		≤8 mA no-load	
Load current / 負載電流		100 mA Max at DC 30V	
Leakage current / 漏電流		≤1.1 mA no-load	
Residual voltage / 殘餘電壓		≤ DC 1.5V	
Insulation resistance / 隔離阻抗		20M Ω min. (DC500V)	
Voltage withstandability / 絕緣耐壓		AC1000V 60Hz for 60 Sec.	
Operating temperature / 工作溫度範圍		-20°C ~ +60°C	
Protection degree / 防水等級		IP64	
Wiring method / 出線方式		Ø4.2 x 2M / 3wires	M8 connector / M8 接頭
Weight / 重量		Approx.60g	Approx.12g

### ◆Dimensions/尺寸圖：

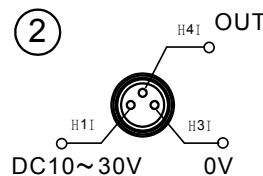
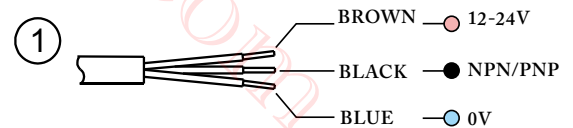
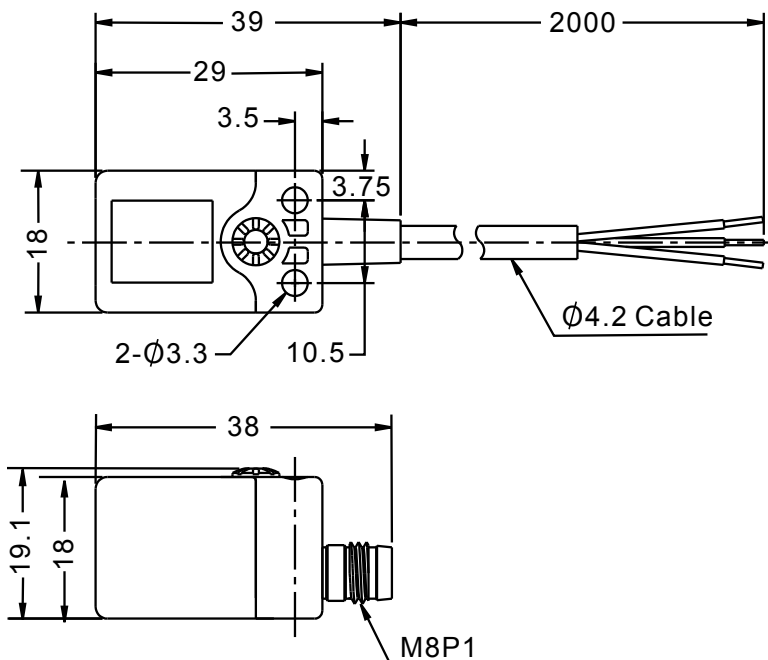

Fiber
Photo Sensor
Area Sensor
Ultrasonic Sensors
Inductive Proximity Sensor
Capacitive Proximity Sensor
Timer / Counter
Others
Accessories