

**RU18****Ultrasonic Sensor**

Fiber

Photo Sensor

Area Sensor

Ultrasonic Sensors

Inductive Proximity Sensor

Capacitive Proximity Sensor

Timer / Counter

Others

Accessories



## 超音波感測器 - RU18

### Ultrasonic sensors

#### ◆Characteristic / 特點：

- Working area adjusting (windows teach or single point teach) by teach-in button suitable for all models for all models for a fast coming into work. /操作簡易，只需通過按鍵教導工作區(窗口設定和單點設定),產品能夠快速的進入工作狀態。
- Multifunction LED indicator: output state, teach-in function, NO/NC configuration. /多功能LED指示燈:LED可顯示輸出狀態,設定狀態,和NO/NC狀態等。
- Plastic housing, Ip67 protection degree / 特殊塑料外殼,防水等級最高可達IP67。
- Approvals: CE / 通過CE 認證,品質可靠有保證。
- It is easy to detect transparent objects. / 最適合於透明物體的檢測。

#### ◆Operation chart :



#### Steps / 設定步驟：

Setting A: A-1: Put the object on position A; A-2: Press teach-in button 1 second; A-3: LED twinkles once, setting A ok.

/1. 設定檢測最遠距離：將被測物放置在A點，然後長按設定按鈕(約1 s),待LED燈閃爍1次，即A點設定完成；

Setting B: B-1: Put the object on position B; B-2: Press teach-in button 1 second; B-3: LED twinkles three times, all setting completed.

/2. 設定檢測最近距離：將被測物放置在B點，然後長按設定按鈕(約1 s),待LED燈閃爍3次，即A點設定完成；A點到B點的距離即為感應距離。

# Ultrasonic Sensor

# RU18

## ◆Specifications / 規格表 :

Output Method / 輸出模式	Analogue output 0~10V	RU18-DU90-VK1	RU18-DU160-VK1
	NPN - NO /NC	RU18-DU90-NK1	RU18-DU160-NK1
	PNP - NO /NC	RU18-DU90-PK1	RU18-DU160-PK1
Maximum sensing distance / 最大檢測距離	900 mm		1600 mm
Sensing ranger(Sd) / 有效距離	100 ~900 mm		150 ~ 1600 mm
Beam Angle / 發射角度	±7°		±8°
Frequency transducer / 音頻	300 KHZ		230 KHZ
Repeat accuracy / 重複精度	0.5%		
Temperature range/ 工作溫度	-10°C~+60°C		-20°C~+70°C
Temperature compensation/ 溫度補償	Yes		
Operating voltage / 工作電壓	DC 15~30 V		
Thermal drift / 熱量誤差	< 5%		
Ripple / 漣波因素	5%		
leakage current / 漏電流	<10 μ A @VDC=30V		
Output current / 輸出電流	100 mA		
Minmum load resistance / 最小負載阻抗	1 KΩ (analogue voltage output / 類比電壓輸出10V)		
Adjustment set pint / 調整方式	Teach-in button / 按鍵設定		
Time delay before availability / 開機延遲時間	300ms		
Output Protection / 輸出保護	Polarity reversal; overvoltage pulses; short circuit / 極性逆接&過電壓&短路保護		
Protection degree / 防水等級	IP67		IP67
Housing material / 外殼材質	PBT		
Active Head material / 振動器材質	Epoxy resin / 環氧樹脂		
Tightening torque / 扭力	1 Nm		
Weight / 重量	35 g		
Storage temperature / 保存溫度	-35°C~+70°C (without freezer / 無結霜、結冰)		

## ◆Dimensions/尺寸圖 :

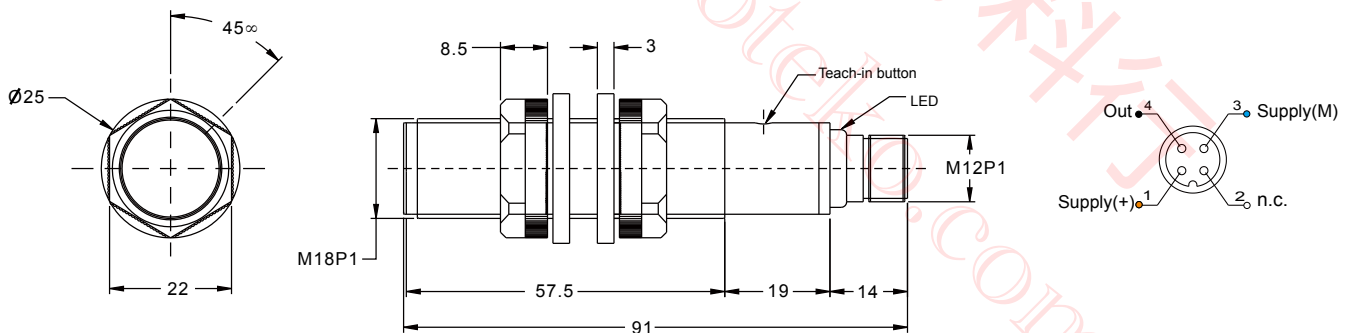

## ◆Wiring diagrams / 接線圖 :

Modelli con uscita digitale PNP NO/NC  
PNP NO/NC models with single digital output

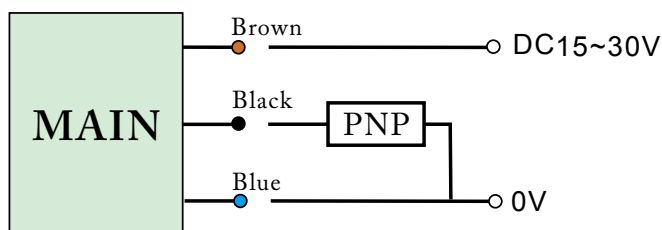

Modelli con uscita analogica in tensione  
Models with single voltage analogica output

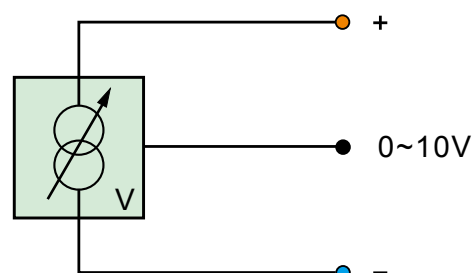

# RU18

## Ultrasonic Sensor

Fiber
Photo Sensor
Area Sensor
Ultrasonic Sensors
Inductive Proximity Sensor
Capacitive Proximity Sensor
Timer / Counter
Others
Accessories

◆ Response diagram / 反應示意圖 :

RU18-DU160

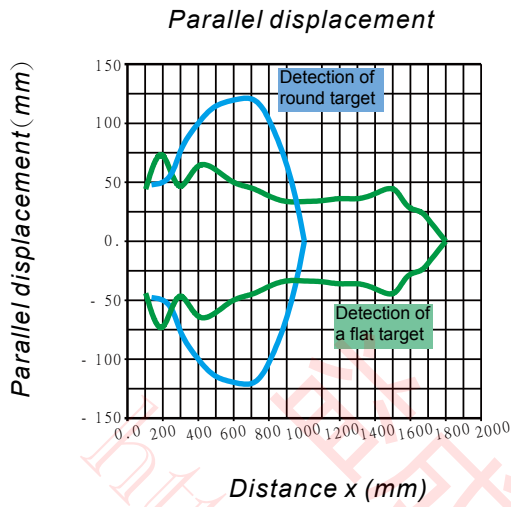

RU18-DU90

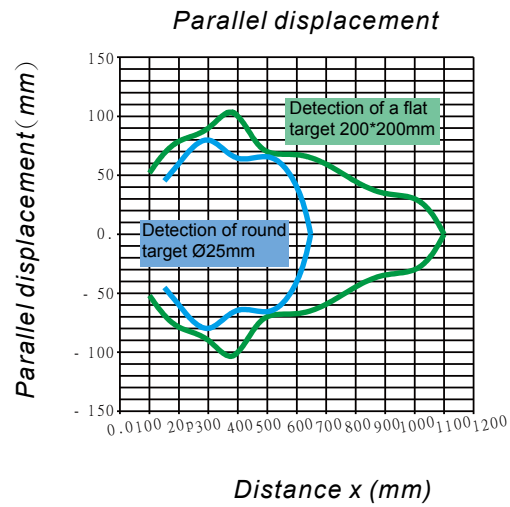

◆ Output chart/輸出圖 :

Models with single digital output

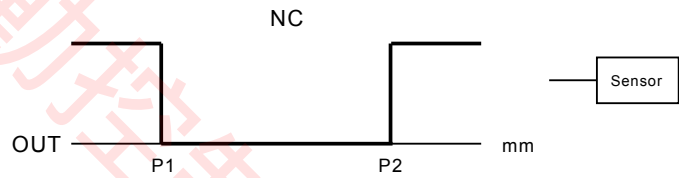
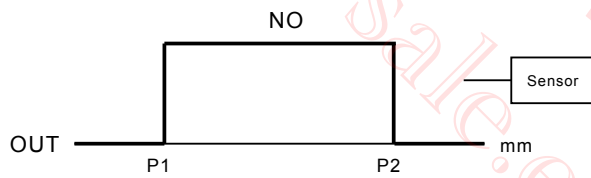

◆ Application / 應用例 :

For transparent object detection. / 透明物體檢測



To detect the level of liquid / 液面檢測

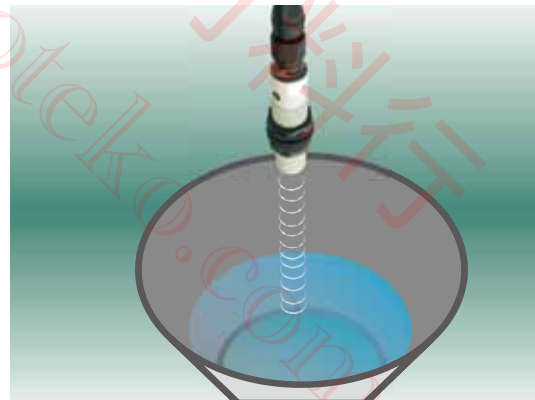

To detect the mirror surface object. / 透明物體檢測

