

# SC

## Tubular Inductive Proximity Sensor

### ◆ Wiring diagrams / 接線圖 :

• DC versions / 直流接線 :

\* SC□-N□

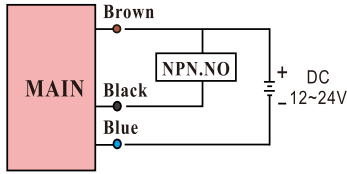

\* SC□-P□

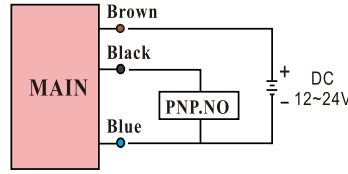

\* SC□-KP2□

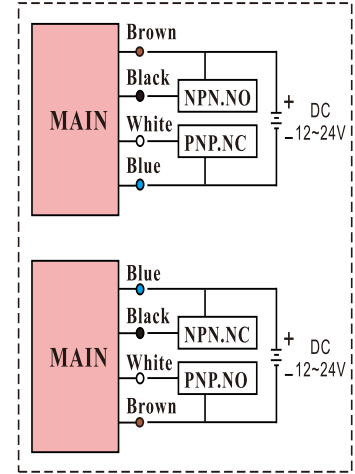

\* SC□-N2□

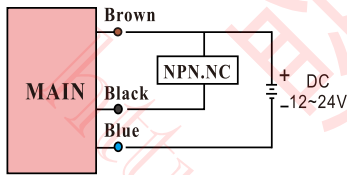

\* SC□-P2□

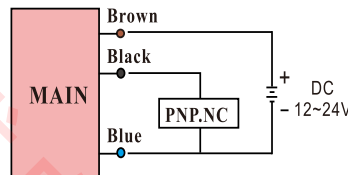

• AC versions / 交流接線 :

SC□-A□

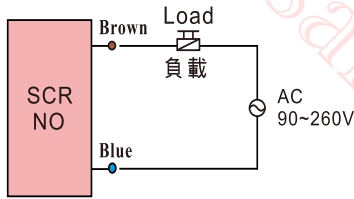

\* SC□-A2□

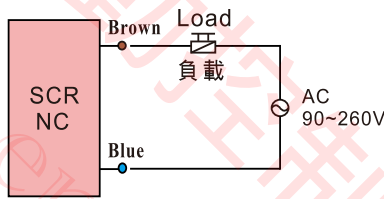

### ◆ Precautions proper installation / 安裝注意事項 :

• SC/TSC系列

Mounting with nut. / 螺母安裝

Shielded / 隔離型

Unshielded / 非隔離型

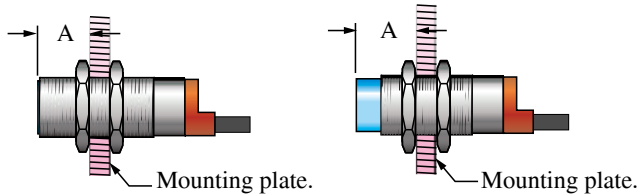

Crosstalk prevention. / 相互干擾

When two sensors are mounted in parallel or face to face, keep the minimum distance (according to the table below) to avoid crosstalk.

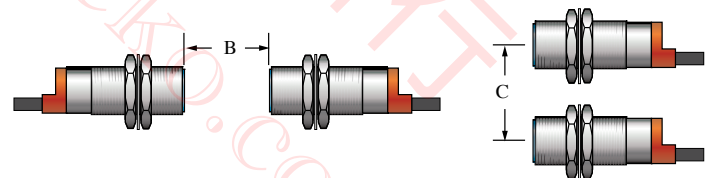

Sensing surface	Model	A (mm)
Shielded / 隔離型	SC0801	≥ 0
	SC1202	≥ 0
	SC1805	≥ 0
	SC3010	≥ 0
Unshielded / 非隔離型	SC0802	≥ 6
	SC1204	≥ 15
	SC1808	≥ 22
	SC3015	≥ 30
	SCP3015	≥ 0
	TSC1207	≥ 15
	TSC1815	≥ 22
TSC3025	≥ 30	

Sensing surface	Model	B (mm)	C (mm)
Shielded / 隔離型	SC0801	≥ 20	≥ 15
	SC1202	≥ 30	≥ 20
	SC1805	≥ 50	≥ 35
	SC3010	≥ 100	≥ 70
Unshielded / 非隔離型	SC0802	≥ 80	≥ 60
	SC1204	≥ 120	≥ 100
	SC1808	≥ 200	≥ 110
	SC3015	≥ 300	≥ 200
	SCP3015	≥ 300	≥ 200
	TSC1207	≥ 120	≥ 70
TSC1815	≥ 200	≥ 120	
TSC3025	≥ 300	≥ 350	



# Tubular Inductive Proximity Sensor

## Influenced by surrounding metals. / 周圍金屬影響

The surrounding metals will influence the sensing performance. Please keep the minimum sensing distance according to the table below.

### Shielded / 隔離型

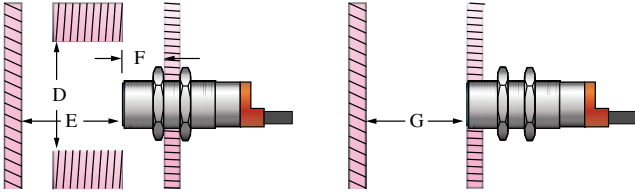

Model	D (mm)	E (mm)	F (mm)	G (mm)
SC0801	≥ 12	≥ 4	≥ 0	≥ 4
SC1202	≥ 18	≥ 8	≥ 0	≥ 8
SC1805	≥ 27	≥ 20	≥ 0	≥ 20
SC3010	≥ 45	≥ 40	≥ 0	≥ 40

### Unshielded / 非隔離型

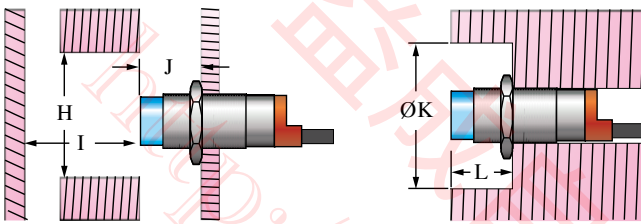

Model	H (mm)	I (mm)	J (mm)	K (mm)	L (mm)
SC0802	≥ 22	≥ 8	≥ 6	≥ 22	≥ 6
SC1204	≥ 36	≥ 20	≥ 15	≥ 40	≥ 15
SC1808	≥ 54	≥ 40	≥ 22	≥ 55	≥ 22
SC3015	≥ 90	≥ 70	≥ 30	≥ 90	≥ 30
SCP3015	≥ 90	≥ 70	≥ 30	≥ 90	≥ 30
TSC1207	≥ 50	≥ 25	≥ 15	≥ 50	≥ 15
TSC1815	≥ 70	≥ 48	≥ 25	≥ 70	≥ 25
TSC3025	≥ 120	≥ 90	≥ 45	≥ 120	≥ 45

### • SN/TSN系列

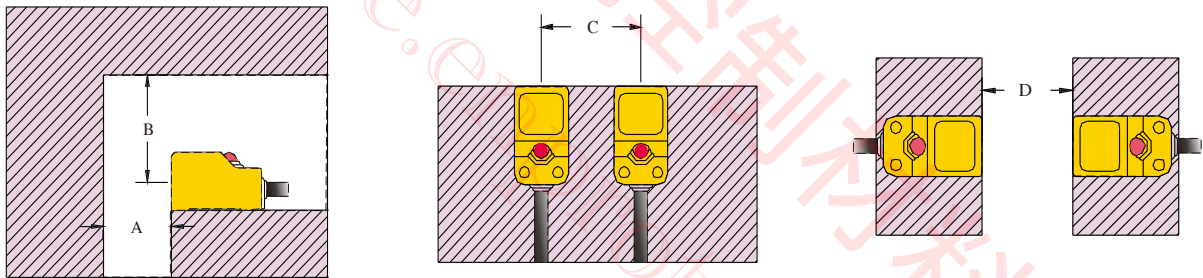

Model	A (mm)	B (mm)	C (mm)	D (mm)
SND04	≥ 15	≥ 20	≥ 30	≥ 30
RN04	≥ 15	≥ 20	≥ 30	≥ 30
RN05	≥ 20	≥ 25	≥ 40	≥ 40
SN10	≥ 40	≥ 30	≥ 60	≥ 60
SN20	≥ 80	≥ 45	≥ 80	≥ 80
TSN18	≥ 72	≥ 54	≥ 180	≥ 180
TSN28	≥ 112	≥ 63	≥ 280	≥ 280

Fiber

Photo Sensor

Area Sensor

Ultrasonic Sensors

Inductive Proximity Sensor

Capacitive Proximity Sensor

Timer / Counter

Others

Accessories

**Ø4/M5**

# Tubular Inductive Proximity Sensor

Fiber  
Photo Sensor  
Area Sensor  
Ultrasonic Sensors  
Inductive Proximity Sensor  
Capacitive Proximity Sensor  
Timer / Counter  
Others  
Accessories

◆Shape / 外觀：



◆Specifications / 規格表：

Output type / 輸出模式	NPN N.O.	<b>SC0401-N</b>	<b>SC0501-N</b>
	NPN N.C	-	-
	PNP N.O.	<b>SC0401-P</b>	<b>SC0501-P</b>
	PNP N.C	-	-
	NPN N.O./N.C.	-	-
	PNP N.O./N.C.	-	-
	SCR N.O	-	-
Sensing surface / 檢測方向	Shielded / 隔離型		
Description / 外型	Standard / 標準Ø4		Standard / 標準M5
Standard sensing object / 標準檢測物	Iron 4 x 4 x 1mm		Iron 5 x 5 x 1mm
Sensing distance / 檢出距離	0.8 mm		
Secure sensing distance / 建議距離	0 to 0.5 mm		
Hysteresis / 遲滯	≤ 10 % of sensing distance		
Response time / 反應時間	0.2 ms Max.		
Operating voltage / 工作電壓	DC10 ~ 30 V		
Current consumption / 消耗電流	≤ 10 mA no-load		
Load current / 負載電流	200 mA Max		
Leakage current / 漏電流	≤ 0.1 mA no-load		
Residual voltage / 殘餘電壓	≤ DC 2V 200mA		
Voltage withstandability / 絕緣耐壓	AC1000V 60Hz for 60 Sec.		
Operating temperature / 工作溫度範圍	-25°C ~ + 70°C		
Protection degree / 防水等級	IP 67		
Wiring method / 出線方式	Ø3.5 x 2M x 3 wires		
Weight / 重量	Approx. 26g		Approx. 26g

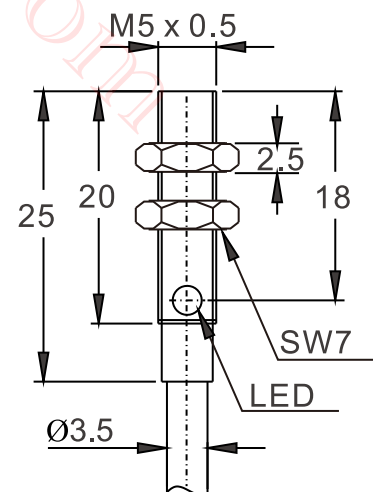
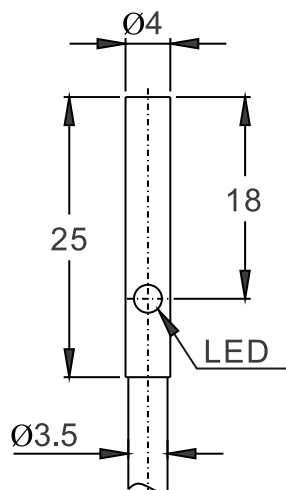

◆Dimensions / 尺寸圖：



# Tubular Inductive Proximity Sensor

# M8

## ◆Specifications / 規格表 :

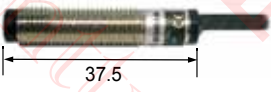
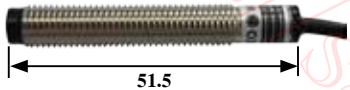
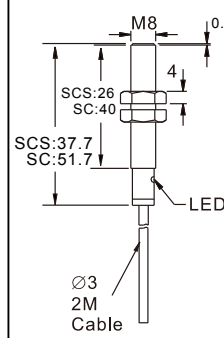
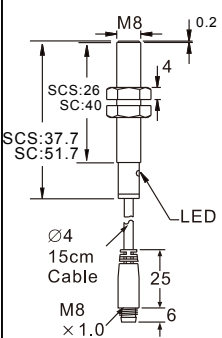
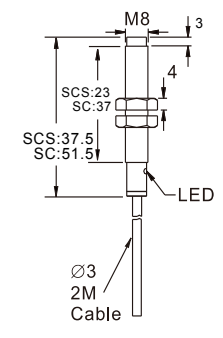
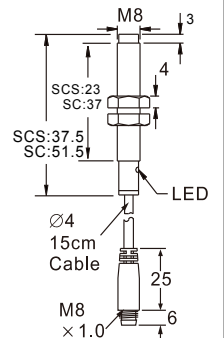
<p><b>SCS0801-□</b></p>  <p>37.7</p> <p><b>SC0801-□D</b></p>  <p>51.7</p> <p><b>SCS0802-□</b></p>  <p>37.5</p> <p><b>SC0802-□</b></p>  <p>51.5</p> <p>&lt;unit:mm&gt;</p>		 <p>M8</p> <p>0.2</p> <p>SCS:26 SC:40</p> <p>4</p> <p>SCS:37.7 SC:51.7</p> <p>LED</p> <p>Ø3 2M Cable</p> <p>14.8</p> <p>12.8</p> <p>&lt;unit:mm&gt;</p>	 <p>M8</p> <p>0.2</p> <p>SCS:26 SC:40</p> <p>4</p> <p>SCS:37.7 SC:51.7</p> <p>LED</p> <p>Ø4 15cm Cable</p> <p>25</p> <p>M8 x 1.0</p> <p>6</p> <p>14.8</p> <p>12.8</p> <p>&lt;unit:mm&gt;</p>	 <p>M8</p> <p>3</p> <p>SCS:23 SC:37</p> <p>4</p> <p>SCS:37.5 SC:51.5</p> <p>LED</p> <p>Ø3 2M Cable</p> <p>14.8</p> <p>12.8</p> <p>&lt;unit:mm&gt;</p>	 <p>M8</p> <p>3</p> <p>SCS:23 SC:37</p> <p>4</p> <p>SCS:37.5 SC:51.5</p> <p>LED</p> <p>Ø4 15cm Cable</p> <p>25</p> <p>M8 x 1.0</p> <p>6</p> <p>14.8</p> <p>12.8</p> <p>&lt;unit:mm&gt;</p>
Output method / 輸出模式	NPN N.O.	SC□0801-N	SC□0801-ND	SC□0802-N	SC□0802-ND
	NPN N.C.	SC□0801-N2	SC□0801-N2D	SC□0802-N2	SC□0802-N2D
	PNP N.O.	SC□0801-P	SC□0801-PD	SC□0802-P	SC□0802-PD
	PNP N.C.	SC□0801-P2	SC□0801-P2D	SC□0802-P2	SC□0802-P2D
	NPN N.O./N.C.	-	-	-	-
	PNP N.O./N.C.	-	-	-	-
	SCR N.O.	-	-	-	-
SCR N.C.	-	-	-	-	
Sensing type / 檢出方式	Shielded / 隔離型		Unshielded / 非隔離型		
Description / 外型	Standard / 標準M8				
Standard sensing object / 標準檢測物	Iron 8 x 8 x 1 mm				
Sensing distance / 檢出距離	1 mm		2 mm		
Secure sensing distance / 建議距離	0 to 0.8 mm		0 to 1.6 mm		
Hysteresis / 遲滯	≤ 10 % of sensing distance				
Response time / 反應時間	1 ms Max.				
Operating voltage / 工作電壓	DC12 ~ 24 V				
Current consumption / 消耗電流	≤ 8 mA no-load				
Load current / 負載電流	100 mA Max at DC 24V				
Leakage current / 漏電流	≤ 1.1 mA no-load				
Residual voltage / 殘餘電壓	≤ DC 1.5V				
Insulation resistance / 隔離阻抗	20MΩ min. (DC500V)				
Voltage withstandability / 絕緣耐壓	AC1000V 60Hz for 60 Sec.				
Operating temperature / 工作溫度	-20°C ~ + 60°C				
Protection degree / 防水等級	IP 66				
Wiring method / 出線方式	Pre-wired Ø3 x 2M / 3-wires	M8 pigtailed type / M8接頭15cm電線式	Pre-wired Ø3 x 2M / 3-wires	M8 pigtailed type / M8接頭15cm電線式	
Weight / 重量	Approx.30g	Approx.12g	Approx.30g	Approx.12g	

Fiber

Photo Sensor

Area Sensor

Ultrasonic Sensors

Inductive Proximity Sensor

Capacitive Proximity Sensor

Timer / Counter



Others

Accessories

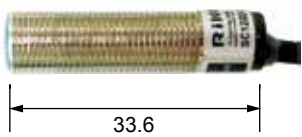
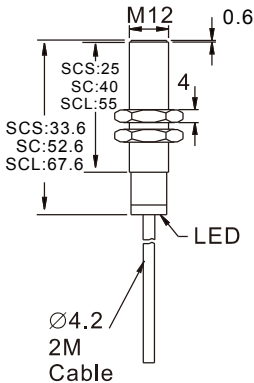
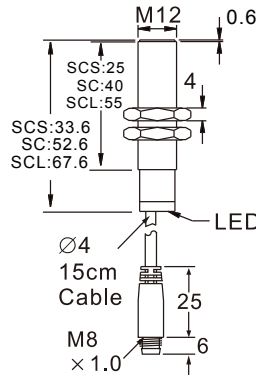
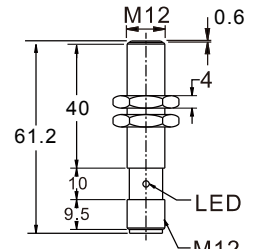
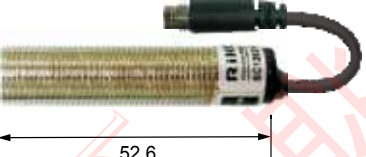
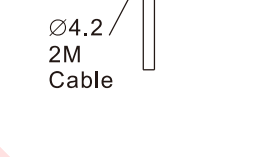
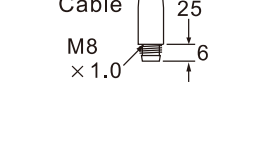

# M12

## Tubular Inductive Proximity Sensor

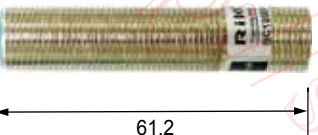
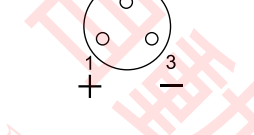
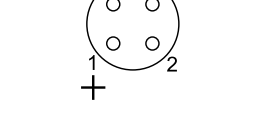
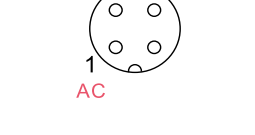
### ◆Specifications / 規格表 :

Fiber	SCS1202-□				
Photo Sensor	SC1202-□D				
Area Sensor	SC1202-□M1				
Ultrasonic Sensors					
Inductive Proximity Sensor					
Capacitive Proximity Sensor					
Timer / Counter					
Others					
Accessories					

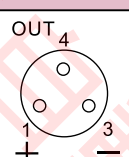
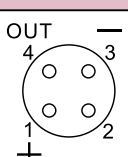
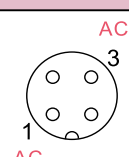
		-□D	-□M1	-□A
				
				

<unit:mm>

Output method / 輸出模式	NPN N.O.	SC□1202-N	SC□1202-ND	SC1202-NM1
	NPN N.C.	SC□1202-N2	SC□1202-N2D	SC1202-N2M1
	PNP N.O.	SC□1202-P	SC□1202-PD	SC1202-PM1
	PNP N.C.	SC□1202-P2	SC□1202-P2D	SC1202-P2M1
	NPN N.O./N.C. PNP N.O./N.C.	SC1202-KP2	-	-
	SCR N.O.	SC1202-A	-	-
	SCR N.C.	SC1202-A2	-	-
Sensing type / 檢出方式	Shielded / 隔離型			
Description / 外型	Standard / 標準M12			
Standard sensing object / 標準檢測物	Iron 12 x 12 x 1 mm			
Sensing distance / 檢出距離	2 mm			
Secure sensing distance / 建議距離	0 to 1.6 mm			
Hysteresis / 遲滯	≤ 10 % of sensing distance			
Response time / 反應時間	DC Type 1 ms Max. or AC Type 50ms			
Operating voltage / 工作電壓	DC 12 ~ 24V or AC90 ~ 260 V			
Current consumption / 消耗電流	DC : ≤ 8 mA no-load or AC : 2 mA Max			
Load current / 負載電流	DC : 100 mA Max at DC 24V or AC : 5 ~ 300 mA Max			
Leakage current / 漏電流	≤ 1.1 mA no-load			
Residual voltage / 殘餘電壓	≤ DC 1.5V			
Insulation resistance / 隔離阻抗	20MΩ min. (DC500V)			
Voltage withstandability / 絕緣耐壓	AC1000V 60Hz for 60Sec.			
Operating temperature / 工作溫度	-20°C ~ + 60°C			
Protection degree / 防水等級	IP 66			
Wiring method / 出線方式	N/P : Ø4.2x 2M / 3-wires KP2 : Ø4.2x2M / 4-wires AC : Ø4.2x2M / 2-wires	M8 pigtailed type / M8 接頭15cm電線式	M12 plug-in connector type / M12 接頭	
Weight / 重量	SC	Approx. 65g	Approx. 15g	Approx. 20g
	SCL	Approx. 70g	Approx. 20g	Approx. 25g
	SCS	Approx. 60g	Approx. 15g	Approx. 20g

# Tubular Inductive Proximity Sensor

# M12

## ◆Specifications / 規格表 :

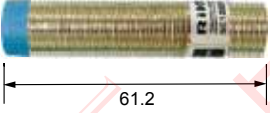
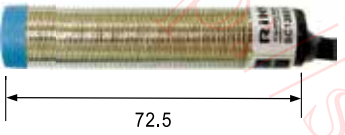
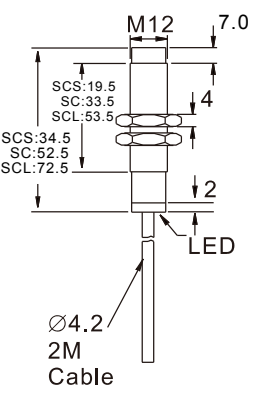
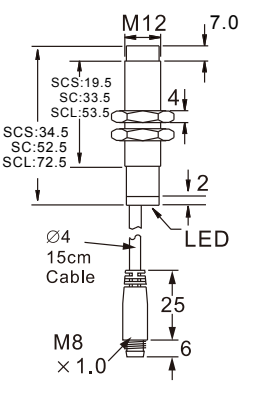
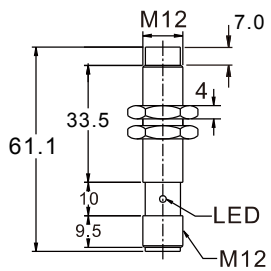
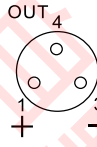
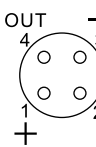
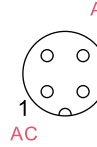
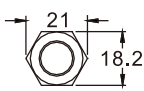
 <p>SCS1204-□D</p> <p>34.5</p>		 <p>SC1204-□M1</p> <p>61.2</p>		 <p>SCL1204-□</p> <p>72.5</p>	
 <p>M12 7.0 SCS:19.5 SC:33.5 SCL:53.5 SCS:34.5 SC:52.5 SCL:72.5 LED Ø4.2 2M Cable</p>		 <p>M12 7.0 SCS:19.5 SC:33.5 SCL:53.5 SCS:34.5 SC:52.5 SCL:72.5 LED Ø4 15cm Cable M8 × 1.0 25 6</p>		 <p>M12 7.0 61.1 33.5 4 10 9.5 LED M12</p>	
		-□D	-□M1	-□A	
		 <p>OUT 4 1 3 +</p>	 <p>OUT 4 3 1 2 +</p>	 <p>AC 3 1 AC</p>	 <p>21 18.2</p>
Output method / 輸出模式	NPN N.O.	SC□1204-N	SC□1204-ND	SC1204-NM1	
	NPN N.C.	SC□1204-N2	SC□1204-N2D	SC1204-N2M1	
	PNP N.O.	SC□1204-P	SC□1204-PD	SC1204-PM1	
	PNP N.C.	SC□1204-P2	SC□1204-P2D	SC1204-P2M1	
	NPN N.O./N.C. PNP N.O./N.C.	SC1204-KP2	-	-	
	SCR N.O.	SC1204-A	-	-	
	SCR N.C.	SC1204-A2	-	-	
Sensing type / 檢出方式	Unshielded / 非隔離型				
Description / 外型	Standard / 標準M12				
Standard sensing object / 標準檢測物	Iron 12 × 12 × 1 mm				
Sensing distance / 檢出距離	4 mm				
Secure sensing distance / 建議距離	0 to 3.2 mm				
Hysteresis / 遲滯	≤ 10 % of sensing distance				
Response time / 反應時間	DC Type 2 ms Max. or AC Type 50ms				
Operating voltage / 工作電壓	DC 12 ~ 24V or AC 90 ~ 260V				
Current consumption / 消耗電流	DC : ≤ 8 mA no-load or AC : 2 mA Max				
Load current / 負載電流	DC : 100 mA Max at DC 24V or AC : 5 ~ 300 mA Max				
Leakage current / 漏電流	≤ 1.1 mA no-load				
Residual voltage / 殘餘電壓	≤ DC 1.5V				
Insulation resistance / 隔離阻抗	20M Ω min. (DC500V)				
Voltage withstandability / 絕緣耐壓	AC1000V 60Hz for 60 Sec.				
Operating temperature / 工作溫度	-20°C ~ +60°C				
Protection degree / 防水等級	IP 66				
Wiring method / 出線方式	N/P : Ø4.2x 2M / 3-wires KP2 : Ø4.2x2M / 4-wires AC : Ø4.2x2M / 2-wires	M8 pigtailed type / M8 接頭15cm電線式	M12 plug-in connector type / M12 接頭		
Weight / 重量	SC	Approx. 65g	Approx. 15g	Approx. 20g	
	SCL	Approx. 70g	Approx. 20g	Approx. 25g	
	SCS	Approx. 60g	Approx. 15g	Approx. 20g	

Fiber

Photo Sensor

Area Sensor

Ultrasonic Sensors

Inductive Proximity Sensor

Capacitive Proximity Sensor

Timer / Counter



Others

Accessories

# M18

## Tubular Inductive Proximity Sensor

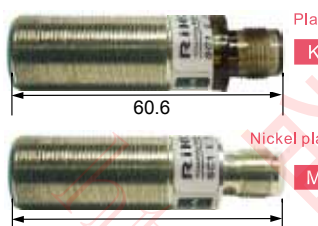
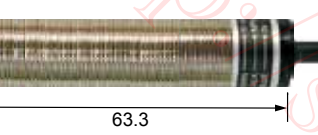
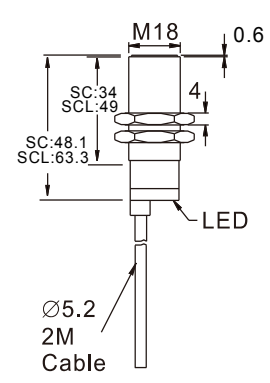
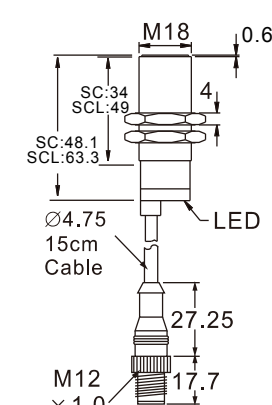
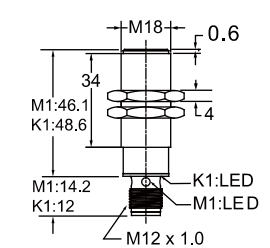
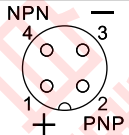
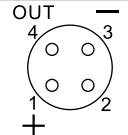
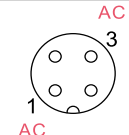
### ◆ Specifications / 規格表 :

Fiber	 <p>SC1805-□K</p>	 <p>SC1805-□K1/M1</p> <p>Plastic K1 Nickel plated brass M1</p>	 <p>SCL1805-□</p>				
Photo Sensor							
Area Sensor							
Ultrasonic Sensors							
Inductive Proximity Sensor							
Capacitive Proximity Sensor							
Timer / Counter							
Others							
Accessories							
		-□KP2 -KP2K1/M1	-□M1 -□K1/M1	-□A			
							
							
		<unit:mm>					
Output method / 輸出模式		NPN N.O.	SC□1805-N	SC□1805-NK	SC1805-NK1/NM1		
		NPN N.C.	SC□1805-N2	SC□1805-N2K	SC1805-N2K1/N2M1		
		PNP N.O.	SC□1805-P	SC□1805-PK	SC1805-PK1/PM1		
		PNP N.C.	SC□1805-P2	SC□1805-P2K	SC1805-P2K1/P2M1		
		NPN N.O./N.C. PNP N.O./N.C.	SC1805-KP2	SC1805-KP2K	-		
		SCR N.O.	SC1805-A	SC1805-AK	-		
		SCR N.C.	SC1805-A2	SC1805-A2K	-		
Sensing type / 檢出方式		Shielded / 隔離型					
Description / 外型		Standard / 標準M18					
Standard sensing object / 標準檢測物		Iron 18 x 18 x 1 mm					
Sensing distance / 檢出距離		5 mm					
Secure sensing distance / 建議距離		0 to 4.0 mm					
Hysteresis / 遲滯		≤ 10 % of sensing distance					
Response time / 反應時間		DC Type 2 ms Max. or AC Type 50ms					
Operating voltage / 工作電壓		DC 12 ~ 24V or AC 90 ~ 260V					
Current consumption / 消耗電流		DC : ≤ 8 mA no-load or AC : 2 mA Max					
Load current / 負載電流		DC : 100 mA Max at DC 24V or AC : 5 ~ 300 mA Max					
Leakage current / 漏電流		≤ 1.1 mA no-load					
Residual voltage / 殘餘電壓		≤ DC 1.5V					
Insulation resistance / 隔離阻抗		20MΩ min. (DC500V)					
Voltage withstandability / 絕緣耐壓		AC1000V 60Hz for 60 Sec.					
Operating temperature / 工作溫度		-20°C ~ + 60°C					
Protection degree / 防水等級		IP 66					
Wiring method / 出線方式		N/P : Ø5.2x 2M / 3-wires KP2 : Ø5.2x2M / 4-wires AC : Ø5.2x2M / 2-wires	M12 pigtailed type / M12 接頭15cm 電線式	M12 plug-in connector type / M12 接頭			
Weight / 重量		SC	Approx. 96g	Approx. 35g	K1:Approx.30g/M1:Approx. 35g		
		SCL	Approx. 116g	Approx. 55g	K1:Approx.50g/M1:Approx. 55g		

# Tubular Inductive Proximity Sensor

# M18

## ◆ Specifications / 規格表 :

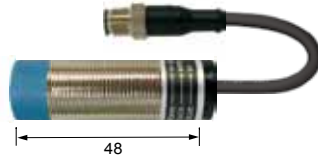
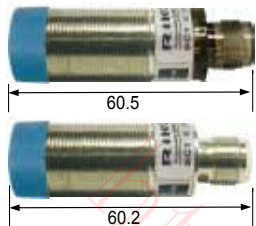
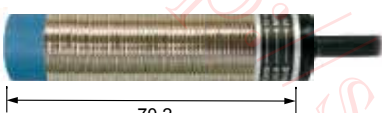
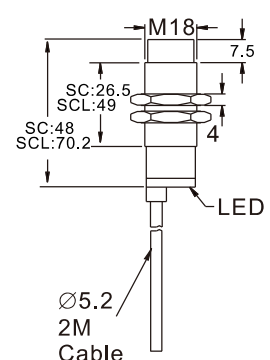
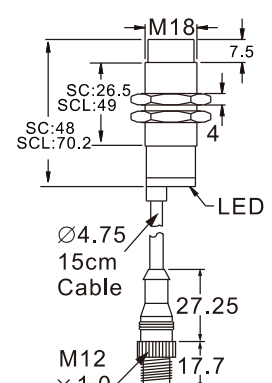
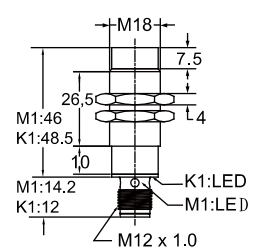
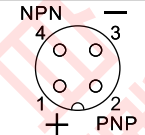
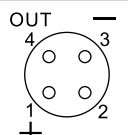
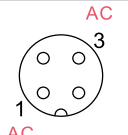
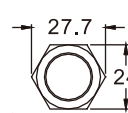
<b>SC1808-□K</b>  48		 60.5 60.2 K1 Plastic M1 Nickel plated brass		 70.2 <unit:mm>		 M18 7.5 SC:26.5 SCL:49 SC:48 SCL:70.2 LED Ø5.2 2M Cable	 M18 7.5 SC:26.5 SCL:49 SC:48 SCL:70.2 LED Ø4.75 15cm Cable 27.25 M12 × 1.0 17.7	 M18 7.5 SC:26.5 SCL:49 SC:48 SCL:70.2 LED M1:46 K1:48.5 L4 10 M1:14.2 K1:12 M1:LED M12 x 1.0
		<b>-KP2</b> <b>-KP2K1/M1</b>		<b>-□M1</b> <b>-□K1/M1</b>		<b>-□A</b>		
		 NPN 4 3 1 2 + PNP		 OUT 4 3 1 2 +		 AC 3 1 AC		
		 27.7 24						
Output method 輸出模式	NPN N.O.	SC□1808-N	SC□1808-NK	SC1808-NK1/M1				
	NPN N.C.	SC□1808-N2	SC□1808-N2K	SC1808-N2K1/M1				
	PNP N.O.	SC□1808-P	SC□1808-PK	SC1808-PK1/M1				
	PNP N.C.	SC□1808-P2	SC□1808-P2K	SC1808-P2K1/M1				
	NPN N.O./N.C. PNP N.O./N.C.	SC1808-KP2	SC1808-KP2K	-				
	SCR N.O.	SC1808-A	SC1808-AK	-				
	SCR N.C.	SC1808-A2	SC1808-A2K	-				
Sensing type / 檢出方式		Unshielded / 非隔離型						
Description / 外型		Standard / 標準M18						
Sensing distance / 檢出距離		8 mm						
Secure sensing distance / 建議距離		0 to 6.4 mm						
Hysteresis / 遲滯		≤ 10 % of sensing distance						
Response time / 反應時間		DC Type 2 ms Max. or AC Type 50ms						
Operating voltage / 工作電壓		DC 12 ~ 24V or AC 90 ~ 260V						
Current consumption / 消耗電流		DC : ≤ 8 mA no-load / AC : 2 mA Max.						
Load current / 負載電流		DC : 100 mA Max at DC 24V or AC : 5 ~ 300 mA Max						
Leakage current / 漏電流		≤ 1.1 mA no-load						
Residual voltage / 殘餘電壓		≤ DC 1.5V						
Insulation resistance / 隔離阻抗		20M Ω min. (DC500V)						
Voltage withstandability / 絕緣耐壓		AC1000V 60Hz for 60 Sec.						
Operating temperature / 工作溫度		-20°C ~ + 60°C						
Protection degree / 防水等級		IP 66						
Wiring method / 出線方式		N/P : Ø5.2x 2M / 3-wires KP2 : Ø5.2x2M / 4-wires AC : Ø5.2x2M / 2-wires	M12 pigtailed type / M12 接頭15cm 電線式	M12 plug-in connector type / M12 接頭				
Weight / 重量	SC	Approx. 90g	Approx. 30g	K1:Approx.25g\M1:Approx. 30g				
	SCL	Approx. 115g	Approx. 55g	K1:Approx.50g\M1:Approx. 55g				

Fiber

Photo Sensor

Area Sensor

Ultrasonic Sensors

Inductive Proximity Sensor

Capacitive Proximity Sensor

Timer / Counter

Others



Accessories



# M30

## Tubular Inductive Proximity Sensor

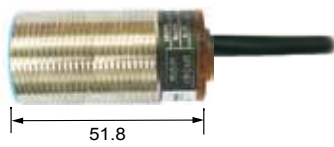
### ◆ Specifications / 規格表 :

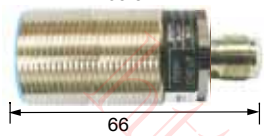
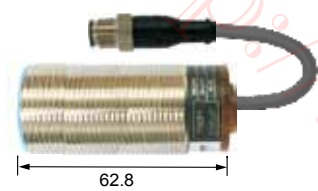
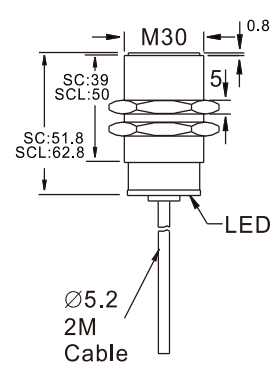
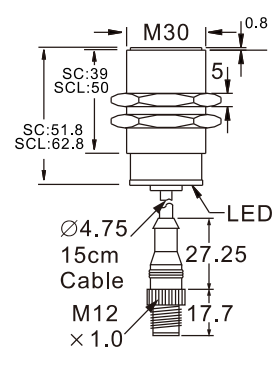
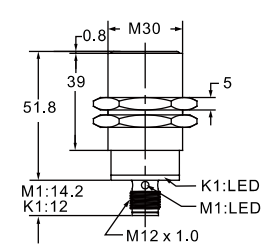
Fiber	 <p>SC3010-□</p> <p>51.8</p>	 <p>SC3010-□ K1/M1</p> <p>63.8</p> <p><b>K1</b> Plastic</p>	 <p>66</p> <p><b>M1</b> Nickel plated brass</p>	 <p>SCL3010-□K</p> <p>62.8</p> <p>&lt;unit:mm&gt;</p>	 <p>M30</p> <p>0.8</p> <p>5</p> <p>SC:39 SCL:50</p> <p>SC:51.8 SCL:62.8</p> <p>LED</p> <p>Ø5.2</p> <p>2M Cable</p>	 <p>M30</p> <p>0.8</p> <p>5</p> <p>SC:39 SCL:50</p> <p>SC:51.8 SCL:62.8</p> <p>LED</p> <p>Ø4.75</p> <p>15cm Cable</p> <p>M12 × 1.0</p> <p>27.25</p> <p>17.7</p>	 <p>M30</p> <p>0.8</p> <p>5</p> <p>39</p> <p>51.8</p> <p>M1:14.2</p> <p>K1:12</p> <p>M12 × 1.0</p> <p>K1:LED</p> <p>M1:LED</p>
Photo Sensor							
Area Sensor							
Ultrasonic Sensors							
Inductive Proximity Sensor							
Capacitive Proximity Sensor							
Timer / Counter							
Others							
Accessories							
Output method / 輸出模式		NPN N.O.	SC□3010-N	SC□3010-NK	SC3010-NK1/M1		
		NPN N.C.	SC□3010-N2	SC□3010-N2K	SC3010-N2K1/M1		
		PNP N.O.	SC□3010-P	SC□3010-PK	SC3010-PK1/M1		
		PNP N.C.	SC□3010-P2	SC□3010-P2K	SC3010-P2K1/M1		
		NPN N.O./N.C. PNP N.O./N.C.	SC3010-KP2	SC3010-KP2K	-		
		SCR N.O.	SC3010-A	SC3010-AK	-		
		SCR N.C.	SC3010-A2	SC3010-A2K	-		
Sensing type / 檢出方式		Shielded / 隔離型					
Description / 外型		Standard / 標準M30					
Standard sensing object / 標準檢測物		Iron 30 x 30 x 1 mm					
Sensing distance / 檢出距離		10 mm					
Secure sensing distance / 建議距離		0 to 8 mm					
Hysteresis / 遲滯		≤ 10 % of sensing distance					
Response time / 反應時間		DC Type 3.3 ms Max. or AC Type 50ms					
Operating voltage / 工作電壓		DC 12 ~ 24V or AC 90 ~ 260V					
Current consumption / 消耗電流		DC : ≤ 8 mA no-load or AC : 2 mA Max.					
Load current / 負載電流		DC : 100 mA Max at DC 24V or AC : 5 ~ 300 mA Max					
Leakage current / 漏電流		≤ 1.1 mA no-load					
Residual voltage / 殘餘電壓		≤ DC 1.5V					
Insulation resistance / 隔離阻抗		20M Ω min. (DC500V)					
Voltage withstandability / 絕緣耐壓		AC1000V 60Hz for 60 Sec.					
Operating temperature / 工作溫度		-20°C ~ + 60°C					
Protection degree / 防水等級		IP 66					
Wiring method / 出線方式		N/P : Ø5.2x 2M / 3-wires (KP2 : Ø5.2x2M / 4-wires) AC : Ø5.2x 2M / 2-wires	M12 pigtailed type / M12 接頭15cm 電線式	M12 plug-in connector type / M12 接頭			
Weight / 重量		SC SCL	Approx. 145g Approx. 165g	Approx. 90g Approx. 110g	K1:Approx.80g/M1:Approx.100g K1:Approx.100g/M1:Approx. 120g		

# Tubular Inductive Proximity Sensor

# M30

## ◆Specifications / 規格表 :

SC3015-□

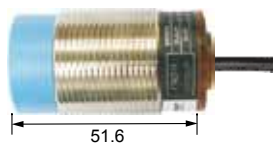

SC3015-□K1/M1

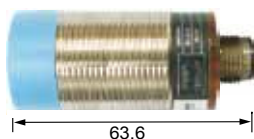

**K1**  
Plastic



**M1**  
Nickel plated brass

SCL3015-□K

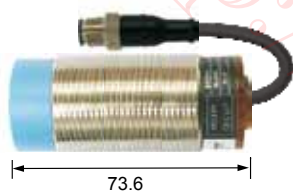

<unit:mm>

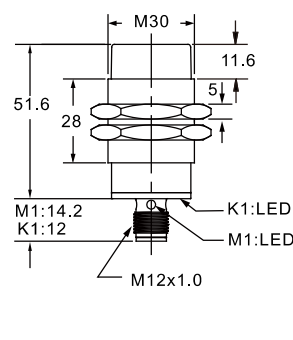
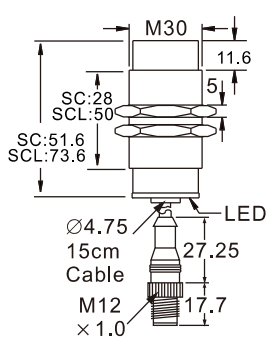
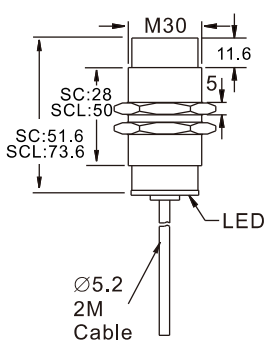

-KP2  
-KP2K1/M1

-□M1  
-□K1/M1

-□A

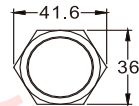
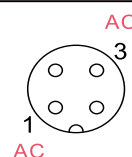
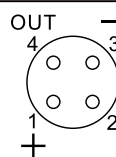
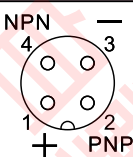

Output method / 輸出模式	NPN N.O.	SC□3015-N	SC□3015-NK	SC3015-NK1/M1
	NPN N.C.	SC□3015-N2	SC□3015-N2K	SC3015-N2K1/M1
	PNP N.O.	SC□3015-P	SC□3015-PK	SC3015-PK1/M1
	PNP N.C.	SC□3015-P2	SC□3015-P2K	SC3015-P2K1/M1
	NPN N.O./N.C. PNP N.O./N.C.	SC3015-KP2	SC3015-KP2K	-
	SCR N.O.	SC3015-A	SC3015-AK	-
	SCR N.C.	SC3015-A2	SC3015-A2K	-
Sensing type / 檢出方式	Unshielded / 非隔離型			
Description / 外型	Standard / 標準M30			
Standard sensing object / 標準檢測物	Iron 30 x 30 x 1 mm			
Sensing distance / 檢出距離	15 mm			
Secure sensing distance / 建議距離	0 ~ 12 mm			
Hysteresis / 滯滯	≤ 10 % of sensing distance			
Response time / 反應時間	DC Type 3.3 ms Max. or AC Type 100ms			
Operating voltage / 工作電壓	DC 12 ~ 24V or AC 90 ~ 260V			
Current consumption / 消耗電流	DC : ≤ 8 mA no-load or AC : 2 mA Max.			
Load current / 負載電流	DC : 100 mA Max at DC 24V or AC : 5 ~ 300 mA Max			
Leakage current / 漏電流	≤ 1.1 mA no-load			
Residual voltage / 殘餘電壓	≤ DC 1.5V			
Insulation resistance / 隔離阻抗	20M Ω min. (DC500V)			
Voltage withstandability / 絕緣耐壓	AC1000V 60Hz for 60 Sec.			
Operating temperature / 工作溫度	-20°C ~ + 60°C			
Protection degree / 防水等級	IP 66			
Wiring method / 出線方式	N/P : Ø5.2x 2M / 3-wires (KP2 : Ø5.2x2M / 4-wires) AC : Ø5.2x 2M / 2-wires	M12 pigtailed type / M12 接頭15cm 電線式	M12 plug-in connector type / M12 接頭	
Weight / 重量	SC	Approx. 135g	Approx. 80g	K1:Approx.70g\M1:Approx. 90g
	SCL	Approx. 170g	Approx. 115g	K1:Approx.105g\M1:Approx. 125g

Fiber

Photo Sensor

Area Sensor

Ultrasonic Sensors

Inductive Proximity Sensor

Capacitive Proximity Sensor

Timer / Counter

Others

Accessories

# M30

## Tubular Inductive Proximity Sensor

### ◆Specifications / 規格表 :

SCP3015-□

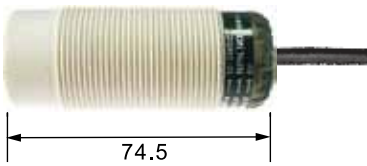

SCP3015-□K



SCP3015-□K1

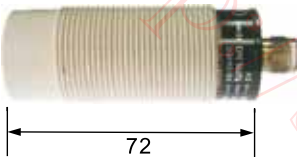

<unit:mm>

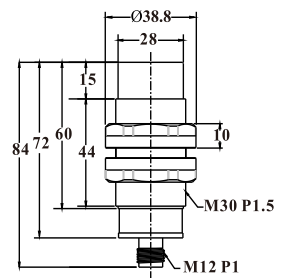
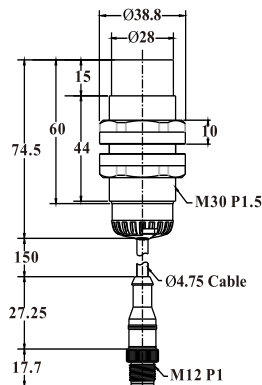
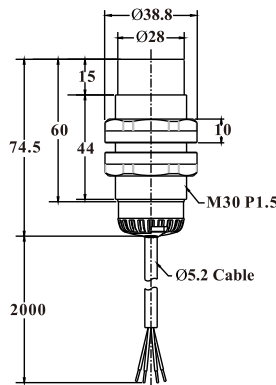

-KP2  
-KP2K1

-□K1  
-□K1

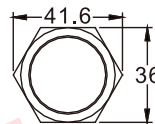
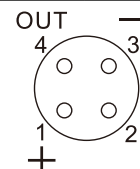
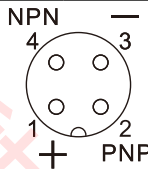

Output method 輸出模式	NPN N.O.	SCP3015-N	SCP3015-NK	SCP3015-NK1
	NPN N.C.	SCP3015-N2	SCP3015-N2K	SCP3015-N2K1
	PNP N.O.	SCP3015-P	SCP3015-PK	SCP3015-PK1
	PNP N.C.	SCP3015-P2	SCP3015-P2K	SCP3015-P2K1
	NPN N.O./N.C. PNP N.O./N.C.	SCP3015-KP2	SCP3015-KP2K	-
	SCR N.O.	-	-	-
	SCR N.C.	-	-	-
Sensing type / 檢出方式	Unshielded / 非隔離型			
Description / 外型	Standard / 標準M30			
Standard sensing object / 標準檢測物	Iron 30 x 30 x 1 mm			
Sensing distance / 檢出距離	15 mm			
Secure sensing distance / 建議距離	0 to 12 mm			
Hysteresis / 遲滯	≤ 10 % of sensing distance			
Response time / 反應時間	3.3ms Max.			
Operating voltage / 工作電壓	DC 12 ~ 24V			
Current consumption / 消耗電流	≤ 30 mA no-load			
Load current / 負載電流	100 mA Max at DC 24V			
Leakage current / 漏電流	≤ 1.1 mA no-load			
Residual voltage / 殘餘電壓	≤ DC 1.5V			
Insulation resistance / 隔離阻抗	20M Ω min. (DC500V)			
Voltage withstandability / 絕緣耐壓	AC1000V 60Hz for 60 Sec.			
Operating temperature / 工作溫度	-20°C ~ + 60°C			
Protection degree / 防水等級	IP 67			
Wiring method / 出線方式	N/P : Ø5.2x 2M / 3-wire (KP2 : Ø5.2x2M / 4-wire)	M12 pigtailed type / M12 接頭15cm 電線式	M12 plug-in connector type / M12 接頭	
Weight / 重量	Approx.120g	Approx.55g	Approx.50g	